



SHEYENNE / WESTGO

1410

13"

**Owner / Operator Manual
& Parts Book**

701 Lenham Ave. - P.O. Box 647 – Cooperstown, ND 58425
(701) 797-2700 – Fax (701) 797-2584 – www.sheyennemfg.com

This manual includes the following sizes, models, lengths and hopper drive options

13”

1410

Lengths	Mechanical Drive Hopper	Hydraulic Drive Hopper
60'	Tractor PTO	Tractor PTO
70'	Tractor PTO	Tractor PTO
80'	Tractor PTO	Tractor PTO

Descriptions:

- 13” - Nominal auger diameter in inches
- 1410 - Auger, flighting with hanger bearing support
- Lengths - Nominal auger length in feet
- Mechanical Drive Hopper - Tractor power take off
- Hydraulic Drive Hopper - Tractor Hydraulics
- Power Take Off - Basic Power to the Flighting

Note: Special length augers ordered by request

ATTENTION DEALER

Be sure the OWNERS MANUAL remains with the auger when sold. It contains important procedures for safe operation of the auger.

SERIAL NUMBER LOCATION

Always give your dealer the serial number of your Sheyenne/Westgo portable auger when ordering parts, requesting service or for information.

The serial number plate is located where indicated. Please mark this number and other information in the spaces provided. It will be useful for future reference.



Model Number _____

Serial Number _____

Production Year _____

Please enter information below and **SAVE FOR FUTURE REFERENCE**

AUGER WARRANTY

SHEYENNE TOOLING & MANUFACTURING warrants each new product to be free from defects in material and workmanship. This warranty is applicable only for the normal service life expectancy of the machine or components, not to exceed **twelve consecutive months** from the date of delivery of the new SHEYENNE TOOLING & MANUFACTURING product to the original purchaser.

Genuine SHEYENNE TOOLING & MANUFACTURING replacement parts and components will be warranted for 90 days from date of purchase, or the remainder of the original equipment warranty period, whichever is longer.

Under no circumstances will it cover any merchandise or components thereof, which in the opinion of the company, has been subject to negligent handling, misuse, alteration, an accident, or if repairs have been made with parts other than those obtainable through SHEYENNE TOOLING & MANUFACTURING.

Our obligation under this warranty shall be limited to repairing or replacing, free of charge to the original purchaser, any part that in our judgment shall show evidence of such defect, provided further that such part shall be returned within thirty (30) days from date of failure to SHEYENNE TOOLING & MANUFACTURING.

This warranty shall not be interpreted to render us liable for injury or damages of any kind or nature to person or property.

Except as set forth above, **SHEYENNE TOOLING & MANUFACTURING shall have no obligation of liability of any kind on account of any of its equipment and shall not be liable for special or consequential damage. SHEYENNE TOOLING & MANUFACTURING makes no other warranty, express or implied, and, specifically, SHEYENNE TOOLING & MANUFACTURING disclaims any implied warranty of merchantability of fitness for a particular purpose. Some states or provinces do not permit limitations or exclusions of implied warranties of incidental or consequential damages, so the limitations or exclusions in this warranty may not apply.**

This warranty is subject to any existing conditions of supply, which may directly affect our ability to obtain materials or manufacture replacement parts.

SHEYENNE TOOLING & MANUFACTURING reserves the right to make improvements in design or changes in specifications at any time, without incurring any obligations to owners of units previously sold.

No one is authorized to alter, modify or enlarge neither this warranty nor the exclusions, limitations and reservations.

I have read and understand the above instructions and warranty. **Warranty is invalid until all three copies are completed and signed. Customer copy retained, dealer copy in dealer's possession and manufacturer's copy returned.**

Date Purchased _____	Dealership _____
Model Number _____	Serial Number _____
Customer Signature _____	Date _____
Dealer Signature _____	Date _____

Customer Copy

(Keep in this book)

Please enter information below and **SAVE FOR FUTURE REFERENCE**

AUGER WARRANTY

SHEYENNE TOOLING & MANUFACTURING warrants each new product to be free from defects in material and workmanship. This warranty is applicable only for the normal service life expectancy of the machine or components, not to exceed **twelve consecutive months** from the date of delivery of the new SHEYENNE TOOLING & MANUFACTURING product to the original purchaser.

Genuine SHEYENNE TOOLING & MANUFACTURING replacement parts and components will be warranted for 90 days from date of purchase, or the remainder of the original equipment warranty period, whichever is longer.

Under no circumstances will it cover any merchandise or components thereof, which in the opinion of the company, has been subject to negligent handling, misuse, alteration, an accident, or if repairs have been made with parts other than those obtainable through SHEYENNE TOOLING & MANUFACTURING.

Our obligation under this warranty shall be limited to repairing or replacing, free of charge to the original purchaser, any part that in our judgment shall show evidence of such defect, provided further that such part shall be returned within thirty (30) days from date of failure to SHEYENNE TOOLING & MANUFACTURING.

This warranty shall not be interpreted to render us liable for injury or damages of any kind or nature to person or property.

Except as set forth above, **SHEYENNE TOOLING & MANUFACTURING shall have no obligation of liability of any kind on account of any of its equipment and shall not be liable for special or consequential damage. SHEYENNE TOOLING & MANUFACTURING makes no other warranty, express or implied, and, specifically, SHEYENNE TOOLING & MANUFACTURING disclaims any implied warranty of merchantability of fitness for a particular purpose. Some states or provinces do not permit limitations or exclusions of implied warranties of incidental or consequential damages, so the limitations or exclusions in this warranty may not apply.**

This warranty is subject to any existing conditions of supply, which may directly affect our ability to obtain materials or manufacture replacement parts.

SHEYENNE TOOLING & MANUFACTURING reserves the right to make improvements in design or changes in specifications at any time, without incurring any obligations to owners of units previously sold.

No one is authorized to alter, modify or enlarge neither this warranty nor the exclusions, limitations and reservations.

I have read and understand the above instructions and warranty. **Warranty is invalid until all three copies are completed and signed. Customer copy retained, dealer copy in dealer's possession and manufacturer's copy returned.**

Date Purchased _____

Dealership _____

Model Number _____

Serial Number _____

Customer Signature _____

Date _____

Dealer Signature _____

Date _____

Dealer Copy



Manufacturer Copy

PLEASE ENTER INFORMATION BELOW AND RETURN TO SHEYENNE TOOLING AND MANUFACTURING

AUGER WARRANTY

SHEYENNE TOOLING & MANUFACTURING warrants each new product to be free from defects in material and workmanship. This warranty is applicable only for the normal service life expectancy of the machine or components, not to exceed twelve consecutive months from the date of delivery of the new SHEYENNE TOOLING & MANUFACTURING product to the original purchaser.

Genuine SHEYENNE TOOLING & MANUFACTURING replacement parts and components will be warranted for 90 days from date of purchase, or the remainder of the original equipment warranty period, whichever is longer. Warranty is not applicable for normal wear and usage.

Under no circumstances will it cover any merchandise or components thereof, which in the opinion of the company, has been subject to negligent handling, misuse, alteration, an accident, or if repairs have been made with parts other than those obtainable through SHEYENNE TOOLING & MANUFACTURING.

Our obligation under this warranty shall be limited to repairing or replacing, free of charge to the original purchaser, any part that in our judgement shall show evidence of such defect, provided further that such part shall be returned within thirty (30) days from date of failure to SHEYENNE TOOLING & MANUFACTURING.

This warranty shall not be interpreted to render us liable for injury or damages of any kind or nature to person or property.

Except as set forth above, SHEYENNE TOOLING & MANUFACTURING shall have no obligation of liability of any kind on account of any of its equipment and shall not be liable for special or consequential damage. SHEYENNE TOOLING & MANUFACTURING makes no other warranty, express or implied, and, specifically, SHEYENNE TOOLING & MANUFACTURING disclaims any implied warranty of merchantability of fitness for a particular purpose. Some states or provinces do not permit limitations or exclusions of implied warranties of incidental or consequential damages, so the limitations or exclusions in this warranty may not apply.

This warranty is subject to any existing conditions of supply, which may directly affect our ability to obtain materials or manufacture replacement parts.

SHEYENNE TOOLING & MANUFACTURING reserves the right to make improvements in design or changes in specifications at any time, without incurring any obligations to owners of units previously sold.

No one is authorized to alter, modify or enlarge neither this warranty nor the exclusions, limitations and reservations.

I have read and understand the above instructions and warranty. I have also read the owner's manual and understand all safety precautions. **Warranty is invalid until all three copies are completed and signed. Customer copy retained, dealer copy in the dealer's possession and the manufacturer's copy returned.**

Date Purchased _____ Dealership _____

Model Number _____ Serial Number _____

Customer Information: Name (Please Print) _____

Address _____

City _____, State _____, Zip Code _____

E-Mail (If Applicable) _____

Signature _____, Date _____

Dealer Signature _____ Date _____

Please return via; fax, regular mail or e-mail; to:
fax number – (701) 797-2584
address --
Sheyenne Tooling and Manufacturing
PO Box 647
Cooperstown, ND 58425
e-mail – warranty@sheyennemfg.com

TABLE OF CONTENTS

Section	Description	Page
	Augers Included in this Manual	1
	Dealer Instruction	2
	Serial Number Location	3
	Warranty	
	Table of Contents	4
1	Introduction	5
2	Safety Symbol	6 & 7
2.1	General Safety	8
2.2	Operating Safety	9
<u>2.3</u>	<u>Placement Safety & Workplace Hazard Area</u>	<u>10</u>
2.4	Maintenance Safety	11
2.5	Hydraulic Safety	11
2.6	Transport Safety	12
2.7	Storage Safety	13
<u>2.8</u>	<u>Tire Safety</u>	<u>13</u>
2.9	Safety Decals	13
2.10	Sign-Off Form	14
3	Safety Decal Locations	15 – 17
4	Operating Safety	18
<u>4.1</u>	<u>New Operators</u>	<u>18</u>
4.2	Machine Components	19
4.3	Machine Break-In	20
4.4	Pre-Operation Checklist	20
4.5	Attaching / Unhook	21 & 22
<u>4.6</u>	<u>Machine Placement</u>	<u>23 & 24</u>
4.7	Operating	25 - 27
4.8	Transport Safety	28 - 30
4.9	Storage	31
5	Maintenance and Service	32
<u>5.1</u>	<u>Service</u>	<u>32</u>
5.1.1	Fluids and Lubricants	32
5.1.2	Greasing	32
5.1.3	Servicing Intervals	33 & 34
5.1.4	Service Record	35
<u>5.2</u>	<u>Maintenance</u>	<u>36</u>
5.2.1	Shear Pin	36
5.2.2	Clean-out Door	36
5.2.3	Truss Cables	36
5.2.4	Swing Auger Replacement	37
<u>5.2.5</u>	<u>Swing Auger and Hopper Support</u>	<u>37</u>
5.2.6	Hopper Double Constant Velocity Joint (Used on Earlier Augers)	38
5.2.7	Hopper Double Universal Joint	39
6	Timing the Flighting	40
6.1	Hanger Bearings in 1410 Augers	40 & 41
7	Trouble Shooting	42
8	Specifications	43
8.1	Mechanical	43
8.2	Dimensions	44
8.3	Bolt Torque	45
	Notes (For Your Use)	46
9	Parts Section - Table of Contents	47

1 INTRODUCTION

Congratulations on your choice of a Sheyenne/Westgo Portable Auger to compliment your farming operation. This equipment has been designed and manufactured to meet the needs of the discerning farmer for the efficient moving of grain.

Safe, efficient and trouble free operation of your Portable Auger requires that you and anyone else who will be operating or maintaining the Auger, read and understand the Safety, Operation, Maintenance and Trouble Shooting information contained within the Operator's Manual.



Model 1410 - 13" x 80', PTO Drive, Mechanical Drive Hopper

This manual covers the 1410 - 13" Auger made by Sheyenne/Westgo. Included are lengths 60', 70' and 80', PTO drive, mechanical or hydraulic hopper drive option and standard transport or under carriage.

Keep this manual handy for frequent reference and to pass on to new operators or owners. Call your Sheyenne/Westgo dealer if you need assistance, information or additional copies of this manual.

OPERATOR ORIENTATION - The directions left, right, front and rear, as mentioned throughout the manual, are seen from the tractor driver's seat and facing in the direction of travel when the unit is being transported. The front is the intake end of the auger.

**THE SYMBOL SHOWN BELOW IS USED TO
CALL YOUR ATTENTION TO INSTRUCTIONS
CONCERNING YOUR PERSONAL SAFETY**



BE ALERT!

Your Safety is involved

2 SAFETY

SAFETY ALERT SYMBOL



Why is **SAFETY** so important to you?

3 Big Reasons

Accidents Disable and Kill

Accidents Are Costly

Accidents Can Be Avoided

This safety alert symbol appears in this manual and on many of the decals on the auger. It is used to draw your attention to the possibility of personal injury or loss of life. We **urge** you to follow all safety instructions. Be alert to safety issues at **all** times!

In addition you will see the use of **signal words** with the safety messages. The appropriate signal word for each message has been selected using the following guide-lines:

DANGER – An immediate and specific hazard which **will** result in severe personal injury or death if the proper precautions are not taken.

WARNING – A specific hazard or unsafe practice which **could** result in severe personal injury or death if proper precautions are not taken.

CAUTION – Unsafe practices which **could** result in personal injury if proper practices are not taken, or as a reminder of good safety practices.

2 SAFETY

YOU are responsible for the safe operation and maintenance of your Sheyenne/Westgo Portable Auger. YOU must ensure that you and anyone else who is going to operate, maintain or work around the Auger be familiar with the operating and maintenance procedures and related Safety information contained in this manual. This manual will take you step -by- step through your working days and alerts you to all good safety practices that should be adhered to while operating the Auger.

Remember, YOU are the key to safety. Good safety practices not only protect you but also the people around you. Make these practices a working part of your safety program. Be certain that EVERYONE operating this equipment is familiar with the recommended operating and maintenance procedures and follows all the safety precautions. Most accidents can be prevented. Do not risk injury or death by ignoring good safety practices.

* Auger owners must give operating instructions to operators or employees before allowing them to operate the Auger, and at least annually thereafter per OSHA (Occupational Safety and Health Administration) regulation 1928.57.

* The most important safety device on this equipment is a safe operator. It is the operators responsibility to read and understand All Safety and Operating instructions in the manual and to follow them. All accidents can be avoided.

* A person who has not read and understood all operating and safety instructions is not qualified to operate the machine. An untrained operator exposes himself and bystanders to possible serious injury or death.

* Do not modify the equipment in any way. Unauthorized modification may impair the function and/or safety and could affect the life of the equipment.

Work Safely !

2.1 GENERAL SAFETY

1. Read and understand the Operator's Manual before operating, maintaining or adjusting the Auger.



2. Only trained competent persons shall operate the Auger. An untrained operator is not qualified to operate this machine.

3. Have a first-aid kit available for use should the need arise and know how to use it.

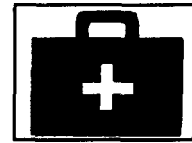

4. Do not allow children, spectators or bystanders within hazard area of machine.

5. Wear appropriate protective gear. This list includes but is not limited to:

- A hard hat,
- Protective shoes with slip resistant soles
- Protective goggles
- Heavy gloves
- Hearing protection
- Respirator or filter mask

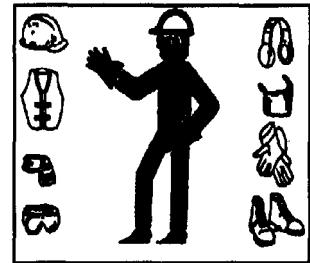

6. Stop the engine, place all controls in neutral, set park brake, remove ignition key and wait for all moving parts to stop before servicing, adjusting, repairing, or unplugging.

7. Review safety related items annually with all personnel who will be operating or maintaining the Auger.

8. Have another person nearby who can shut down the auger in case of an accident. It is good practice to always work with a second person around augers.

Think SAFETY !

2.2 OPERATING SAFETY

1. Read and understand the Operator's Manual and all safety signs before using.
2. Stop the tractor engine, place all controls in neutral, set park brake, remove ignition key and wait for all moving parts to stop before servicing, adjusting, repairing or unplugging.
3. Clear the area of all bystanders, especially children, before starting.
4. Be familiar with machine hazard area. If anyone enters hazard area, shut down machine immediately. Clear the area before restarting.
5. Keep hands, feet, hair and clothing away from all moving and/or rotating parts.
6. Do not allow riders on the Auger or tractor when transporting.
7. Stay away from overhead obstructions and power lines during operation and transporting. Electrocution can occur without direct contact.
8. Do not operate machine when any guards are removed.
9. Set park brake on tractor before starting.
10. Lower Auger to its lowest position when transporting or when not in use.
11. Have another person nearby who can shut down the auger in case of an accident. It is good practice to always work with a second person around augers.
12. Inspect lift cable before using auger. Replace if frayed or damaged.
13. Make certain the lift cable is properly seated in cable pulleys.
14. Ensure that auger is empty before raising or lowering.
3. Keep Auger as low as possible.
4. Chock Auger and tractor wheels front and rear before operating.
5. Locate Auger to provide ample space for grain vehicles to unload.
6. Keep Auger as low as possible when moving. Raise only when it is next to storage facility.
7. Be familiar with the machine hazard area. If anyone enters hazard area, shut down machine immediately. Clear the area before restarting.
8. Operate the auger on level ground free of debris. If ground is uneven, anchor the auger to prevent tipping or upending.

IMPORTANT

BEFORE RAISING OR PLACEMENT OF ENSURE THAT GROUND IS REASONABLY LEVEL. AUGER COULD TOPPLE IF GROUND IS TOO UNEVEN, DAMAGING EQUIPMENT AND/OR CAUSING PERSONAL INJURY.

NOTE: If auger wheels are partially or fully buried in snow or grain, do not attempt to move auger until snow or grain has been cleared away from auger wheels. Failure to heed may cause damage to auger and/or serious injury.

IMPORTANT

WHEN RELEASING AUGER FROM THE TOWING VEHICLE, TEST THE INTAKE END FOR DOWNWARD WEIGHT. DO NOT RAISE THE INTAKE END ABOVE DRAW BAR HEIGHT. WHEN THE INTAKE END IS ELEVATED TOO HIGH WITH AUGER IN RAISED POSITION, THE BALANCE OF WEIGHT QUICKLY TRANSFERS TO THE DISCHARGE END, CAUSING THE AUGER TO UPEND.

NOTE: Winch must have clicking sound when raising auger. If clicking sound stops, retain grip on handle, lower the auger fully and repair ratchet.

2.3 PLACEMENT SAFETY

1. Move only with a tractor. Never move by hand.
2. Stay away from overhead power lines when moving Auger. Electrocution can occur without direct contact.

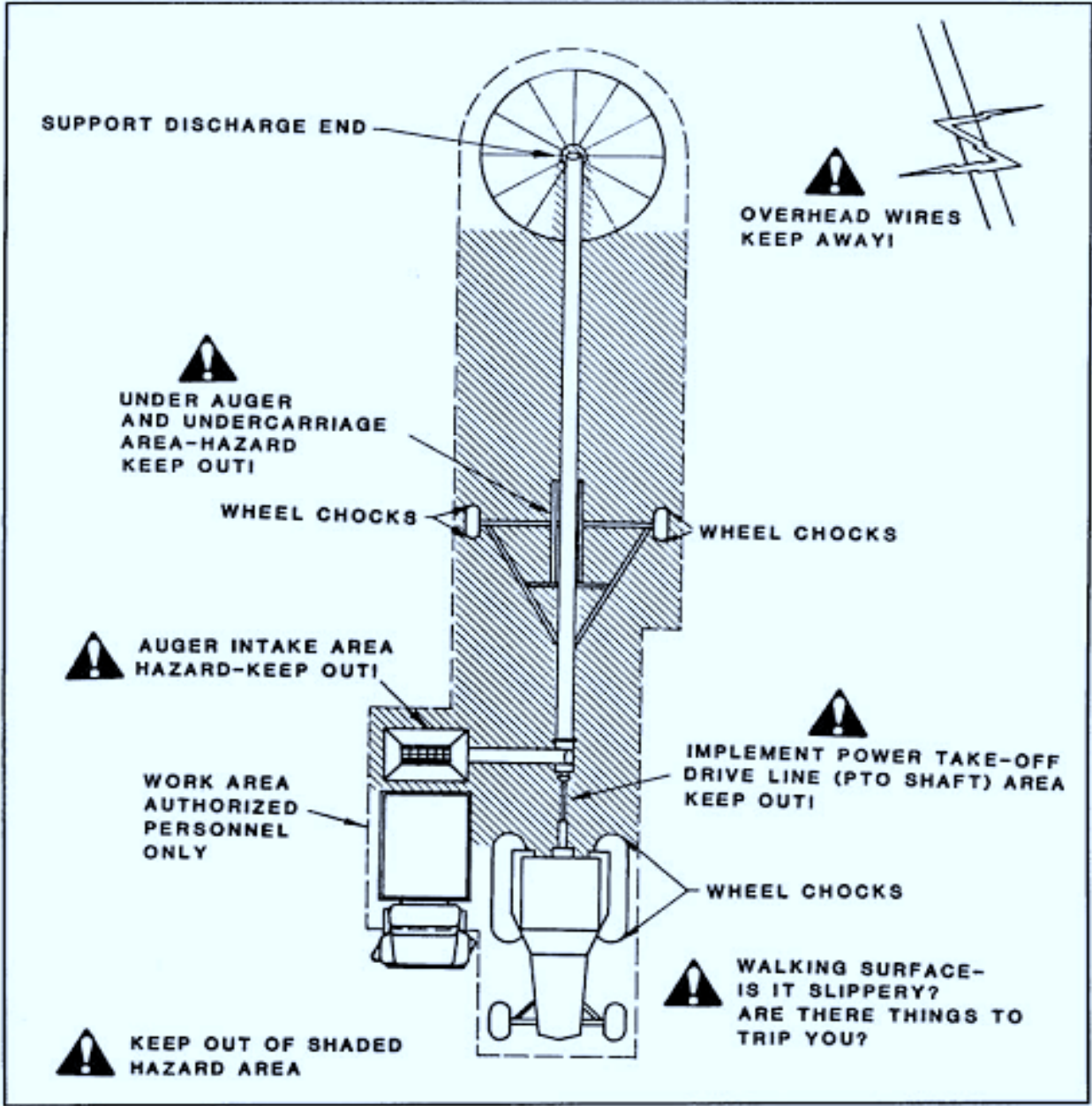

WORKPLACE HAZARD AREA
TRACTOR PTO DRIVE

2.4 MAINTENANCE SAFETY

1. Review the Operator's Manual and all safety items before working with, maintaining or operating the Auger.

2. Stop the engine, place all controls in neutral set park brake, remove ignition key and wait for all moving parts to stop before servicing, adjusting, repairing or unplugging.

3. Follow good shop practices:

-Keep service area clean and dry.



-Be sure electrical outlets and tools are properly grounded.

-Use adequate light for the job at hand.

4. Before applying pressure to a hydraulic system, make sure all components are tight and that hoses and couplings are in good condition.

5. Relieve pressure from hydraulic circuit before servicing or disconnecting from tractor.

6. Keep hands, feet, hair and clothing away from all moving and/or rotating parts.

7. Clear the area of bystanders, especially children, when carrying out any maintenance and repairs or making adjustments,

8. Place stands or blocks under the frame before working beneath the machine.

9. Before resuming work, install and secure all guards when maintenance work is completed.

10. Support auger tube before attempting maintenance on the under carriage assembly. Where possible auger should be in the full down position.

11. Keep decals clean. Replace any decal that is damaged or not clearly visible.

2.5 HYDRAULIC SAFETY

1. Always place all tractor hydraulic controls in neutral before disconnecting from tractor or working on hydraulic system.

2. Make sure that all components in the hydraulic system are kept in good condition and are clean.

3. Replace any worn, cut, abraded, flattened or crimped hoses.

4. Do not attempt any makeshift repairs to the hydraulic fittings or hoses by using tape, clamps or cements. The hydraulic system operates under extremely high-pressure. Such repairs will fail suddenly and create a hazardous and unsafe condition.

5. Wear proper hand and eye protection when searching for high-pressure hydraulic leak.

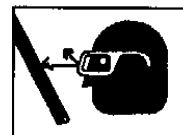

Use a piece of paper, or cardboard, or wood as a backstop instead of hands to isolate and identify a leak.

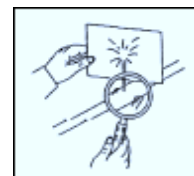

6. If injured by a concentrated high-pressure stream of hydraulic oil, seek medical attention **immediately**. Serious infection or toxic reaction can develop from hydraulic fluid piercing the skin surface.

2.6 TRANSPORT SAFETY

1. Read and understand ALL the information in the Operator's Manual regarding procedures and SAFETY when moving or transporting the Auger.
2. Check with local authorities regarding Auger transport on public roads. Obey all applicable laws and regulations.
3. Always travel at a safe speed. Use caution when making corners or meeting traffic.
4. Make sure the SMV (Slow Moving Vehicle) emblem and all the lights and reflectors that are required by the local highway and transport authorities are in place, are clean and can be seen clearly by all overtaking and oncoming traffic.
5. Do not allow riders on the Auger or the tractor when transporting.
6. Attach Auger to towing vehicle with a bolt, washer and double nut. Always attach the safety chain.
7. Lower Auger to its lowest position for transporting.
8. Keep to the right and yield the right-of-way to allow faster traffic to pass. Drive on the road shoulder, if permitted by law.
9. Do not exceed 20 mph (32 km/h). Reduce speed on rough roads and surfaces.
10. Stay away from overhead obstructions and power lines when transporting. Electrocutation can occur without direct contact.
11. Always use hazard warning flashers on tractor when transporting unless prohibited by law.

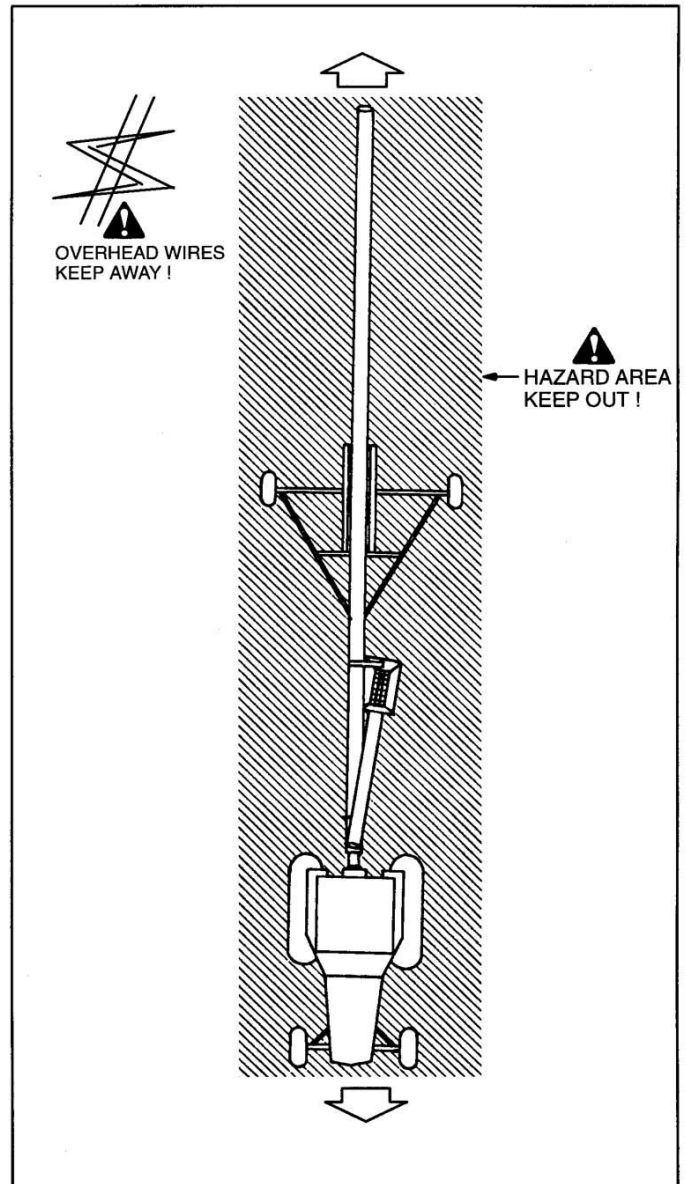

TRANSPORTING HAZARD AREA

NOTE: *If auger wheels are partially or fully buried in snow or grain, do not attempt to move auger until snow or grain has been cleared away from the wheels. Failure to heed may cause damage to auger and/or serious injury.*

2.7 STORAGE SAFETY

1. Store the auger in an area away from human activity.
2. Do not permit children to play on or around the stored machine.
3. Lower the auger to its lowest position for storage unless placed in its operating position.

2.8 TIRE SAFETY

1. Failure to follow proper procedures when mounting a tire on a wheel or rim can produce an explosion which may result in serious injury or death.
2. Do not attempt to mount a tire unless you have the proper equipment and experience to do the job.
3. Have a qualified tire dealer or repair service perform required tire maintenance.
4. When replacing worn tires, make sure they meet the original tire specifications. Never under-size.

2.9 SAFETY DECALS

1. Keep safety decals and signs clean and legible at all times.
2. Replace safety decals that displayed a safety sign that are missing or have become illegible.
3. Replaced parts that displayed a safety sign should also display the current sign.
4. Safety decals or signs are available from your Dealers Parts Department or the factory.

How to Install Safety Decals:

1. Be sure that the installation area is clean and dry.
2. Decide on the exact position before you remove the backing paper.
3. Remove the smallest portion of the split backing paper.
4. Align the decal over the specified area and carefully press the small portion with the exposed sticky backing in place.
5. Slowly peel back the remaining paper and carefully smooth the remaining portion of the decal in place.
6. Small air pockets can be pierced with a pin and smoothed out using the piece of decal backing paper.

2.10 SIGN-OFF FORM

Sheyenne/Westgo follows the General Safety Standards specified by the American Society of Agricultural Engineers (ASAE) and the Occupational Safety and Health Administration (OSHA). Anyone who will be operating and/ or maintaining the Portable Auger must read and clearly understand All Safety, operating and Maintenance information presented in this manual.

Do not operate or allow anyone else to operate this equipment until such information has been reviewed. Annually review this information

before the season start-up.

Make these periodic reviews of SAFETY and OPERATION a standard for all of your equipment. We feel that an untrained operator is unqualified to operate this machine.

A sign off sheet is provided for your record keeping to show that all personnel who will be working with the equipment have read and understand the information in the Operator's Manual and have been instructed in the operation of the equipment.

SIGN-OFF FORM

DATE	EMPLOYEES SIGNATURE	EMPLOYERS SIGNATURE

3. SAFETY DECAL LOCATIONS

The types of decals and locations on the equipment are shown in the illustration below. Good safety requires that you familiarize yourself with the various Safety Decals, the type of warning and the area, or particular function related to that area, that requires your SAFETY AWARENESS.

Think SAFETY! Work SAFELY!



100-3-1367
(4) Places

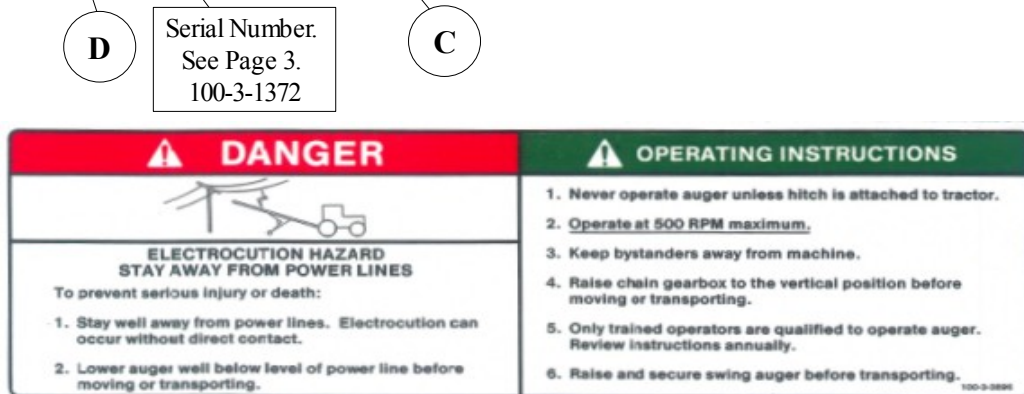

100-3-3696
(2) Places

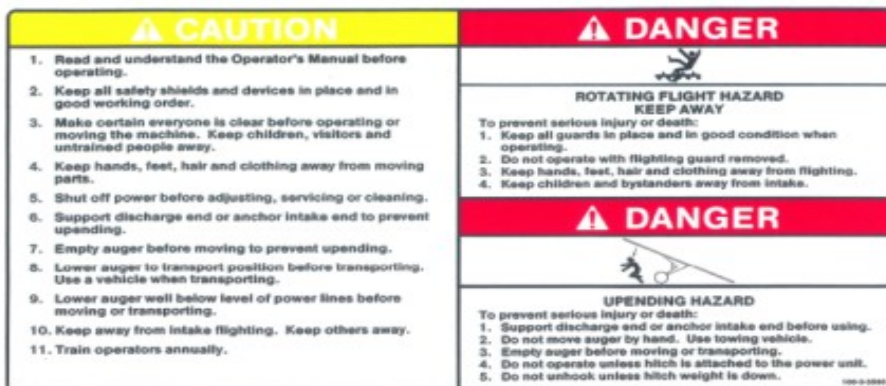

100-3-3593



100-3-3623

REMEMBER - If Safety Decals have been damaged, removed, become illegible or parts replaced without decals. new decals must be applied. New decals are available from your authorized dealer.

Continued on next page

The types of decals and locations on the equipment are shown in the illustration below. Good safety requires that you familiarize yourself with the various Safety Decals, the type of warning and the area, or particular function related to that area, that requires your SAFETY AWARENESS.

Think SAFETY!

Work SAFETY!

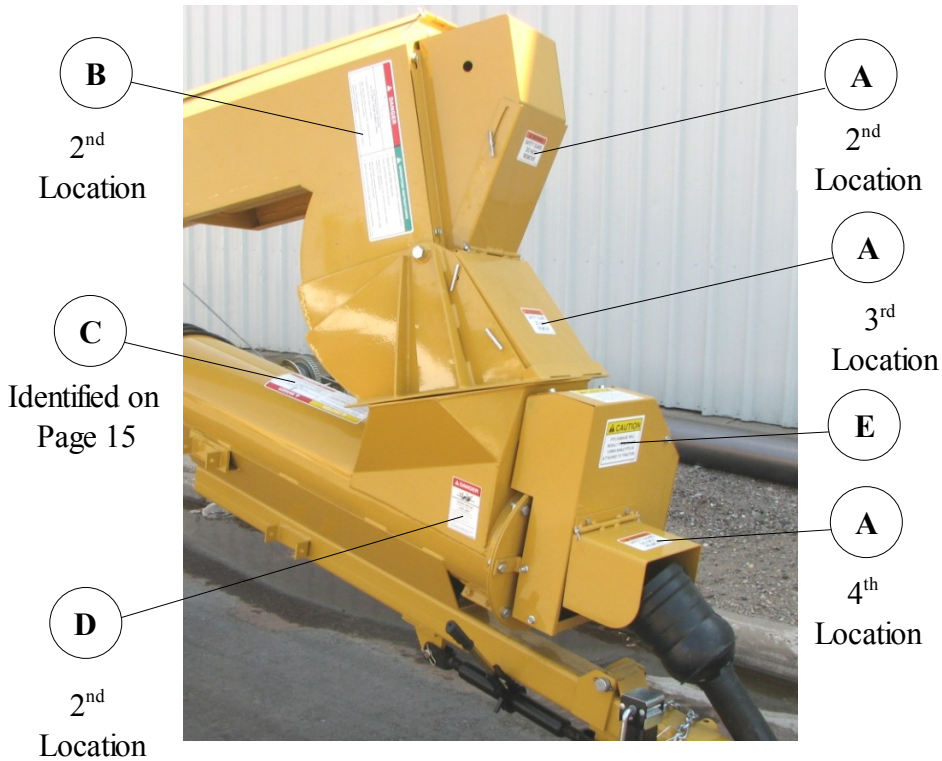

100-3-4937



505-3-0315

REMEMBER – If safety decals have been damaged, removed, become illegible or parts replaced without decals, new decals must be applied. New decals are available from your authorized dealer.

The types of decals and locations on the equipment are shown in the illustration below. Good safety requires that you familiarize yourself with the various Safety Decals, the type of warning and the area, or particular function related to that area, that requires your SAFETY AWARENESS.

Think SAFETY!

Work SAFETY!



G

100-3-4939



H

Decal supplied by vendor.
If replacement needed, use
100-3-3623



L

Logo

100-3-4460

I

100-3-3692

J

100-3-4462

K

100-3-4466

REMEMBER – If safety decals have been damaged, removed, become illegible or parts replaced without decals, new decals must be applied. New decals are available from your authorized dealer.

4 OPERATION



OPERATING SAFETY

1. Read and understand the Operator's Manual and all safety signs before using.
2. Stop the engine, place all controls in neutral, set park brake, remove ignition key and wait for all moving parts to stop before servicing, adjusting, repairing or unplugging.
3. Clear the area of all bystanders, especially children, before starting.
4. Be familiar with machine hazard area. If anyone enters hazard area, shut down (machine immediately. Clear the area before restarting.
5. Keep hands, feet, hair and clothing away from all moving and/or rotating parts.
6. Do not allow riders on the Auger or tractor when transporting.
7. Stay away from overhead obstructions and power lines during operation and transporting. Electrocutation can occur without direct contact.
8. Do not operate machine when any guards are removed.
9. Do not operate unless the flighting guard is installed and secure.
10. Set park brake on tractor before starting.
11. Attach Auger to tractor drawbar before operating.
12. Lower Auger to its lowest position when transporting or when not in use.

4.1 TO THE NEW OPERATOR OR OWNER

The Sheyenne/Westgo Portable Auger is designed to efficiently move grain from a truck, trailer, or wagon into a storage facility. Power is provided by a tractor PTO. Be familiar with the machine before starting.

It is the responsibility of the owner or operator to read this manual and to train all other operators before they start working with the machine. Follow all safety instructions exactly. Safety is everyone's business. By following recommended procedures, a safe working environment is provided for the operator, bystanders and the area around the work site. Untrained operators are not qualified to operate this machine.

Many features incorporated into this machine are the result of suggestions made by customers like you. Read this manual carefully to learn how to operate the machine safely and how to set it to provide maximum efficiency. By following the operating instructions in conjunction with a good maintenance program, your Auger will provide many years of trouble free service.

4.2 MACHINE COMPONENTS

The Portable Auger is a length of rotating flighting enclosed within a tube for moving grain. Grain enters the system through the short swing-away Auger at the lower end. A winch lifts the swing Auger for transport.

Power is provided from a tractor PTO that attaches to the lower end. The swing Auger is driven through a movable chain drive and gearbox to an auxiliary drive line or an optional

hydraulic motor. The movable drive system swings from side-to-side and allows the swing Auger to be used on either side.

A hydraulic cylinder in the frame raises and lowers the machine. It uses hydraulic power from the tractor. Do not raise or lower the auger when the Swing-away hopper is on the ground, mechanical damage can occur.

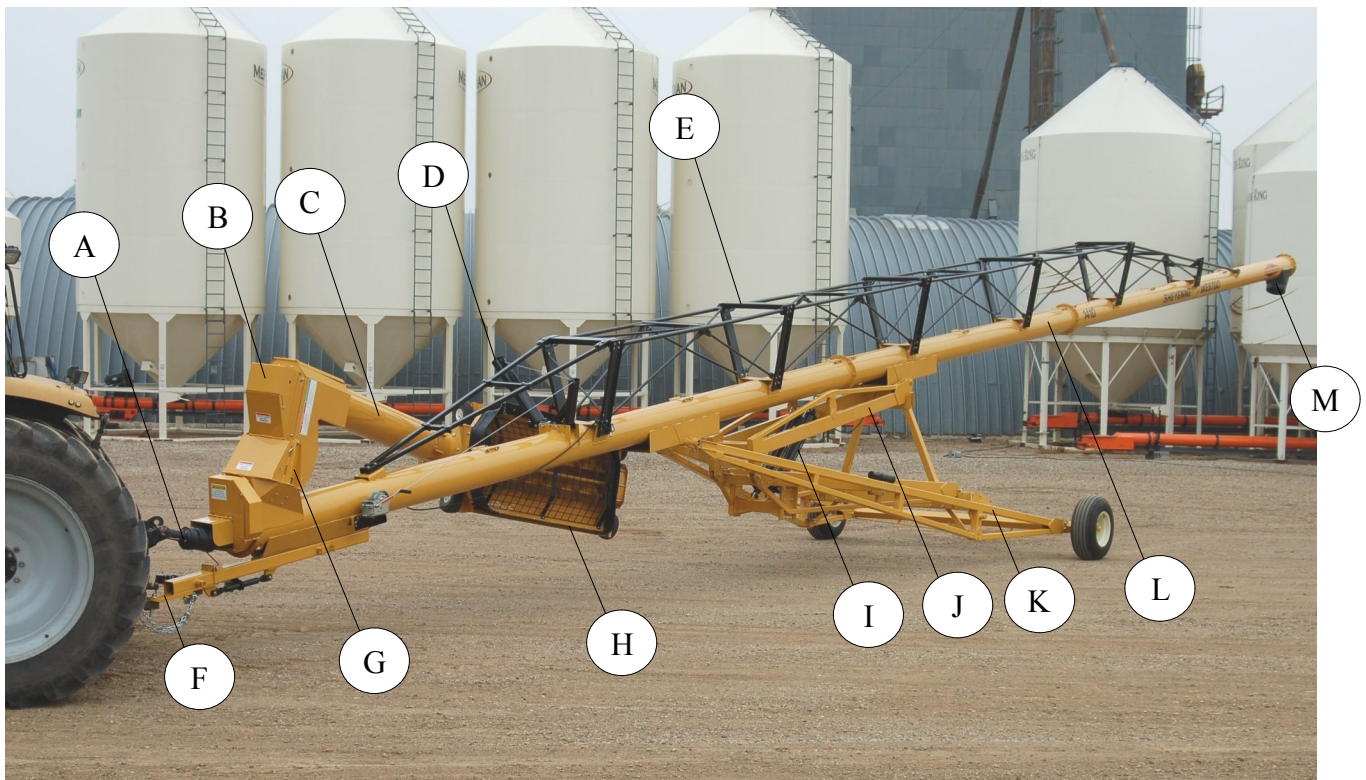

Fig. 1 MACHINE COMPONENTS

A	PTO DRIVE LINE – From Tractor	B	INCLINED SPOUT
C	INCLINED TUBE	D	HOPPER TRANSPORT SUPPORT
E	TRUSSING	F	HITCH
G	LOWER PIVOT	H	SWING AWAY HOPPER – Intake
I	LIFT CYLINDER	J	SISSOR LIFT
K	AUGER TRANSPORT	L	MAIN TUBE
M	AUGER SPOUT - Outlet		

4.3 MACHINE BREAK-IN

Although there are no operational restrictions on the Auger when used for the first time, it is recommended that the following mechanical items be checked:

A. After operating or transporting for 1/2 hour:

1. Re-torque all the wheel bolts.
2. Re-torque fasteners and hardware.
3. Check that all safety decals are installed and legible. Apply new decals if required.
4. Check that no hoses are pinched or being crimped. Re-align as required.
5. Check that all guards are installed and working as intended.
6. Check oil level in gearboxes. Add as required.
7. Check drive chain and tension and alignment. Adjust as required.
8. Lubricate all grease fittings.

B. After operating for 5 hours and 10 hours:

1. Re-torque all wheel bolts, fasteners and hardware.
2. Check hose routing.
3. Check that all guards are installed and working properly.
4. Check safety decals. Install new ones if required.
5. Check gearbox oil level. Add as required.
6. Check drive chain tension and alignment.
7. Then go to the normal servicing and maintenance schedule as defined in the Maintenance Section.

4.4 PRE-OPERATION CHECKLIST

Efficient and safe operation of the Sheyenne/Westgo Portable Auger requires that each operator reads and understands the operating procedures and all related safety precautions outlined in this section. A pre-operation checklist is provided for the operator. It is important for both the personal safety and maintaining the good mechanical condition of the Auger that this checklist is followed.

Before operating the Auger and each time thereafter, the following area should be checked off:

1. Lubricate the machine per the schedule outlined in Section 5 Service and Maintenance.
2. Use only a tractor of adequate power to operate the Auger.
3. Ensure that the machine is properly attached to the tractor drawbar. Use a 5/8 inch bolt, washers and double nut.
4. Check that all guards are installed, secured and functioning as intended. Do not operate with missing or damaged shields.
5. Check work-site. Clean up working area to prevent slipping or tripping.

4.5 ATTACHING / UNHOOKING

It is recommended that the Auger be attached to a tractor whenever it is operated or moved. Follow this procedure when attaching to or unhooking from tractor:

1. Make sure that bystanders, especially small children are clear of the working area.
2. Be sure that there is sufficient room and clearance to back up to the machine.

IMPORTANT !

Do not use a tractor that is equipped with a Quick Hitch! Remove the Quick Hitch before attaching. A Quick Hitch will hit the auger when making turns or it can contact the PTO drive-line if lowered during operation.

3. When moving auger on rough or uneven terrain adjust axle to widest position. **See Fig 2.**

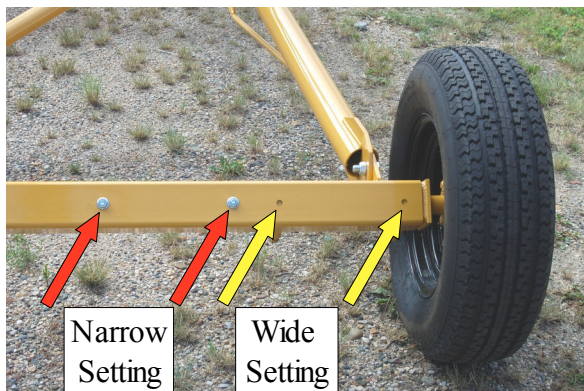

Fig. 2 Axle Adjustment (80' is Different Design)

4. Align the draw-bar of the tractor with the hitch of the auger while backing up.
5. Set the park brake before dismounting.
6. Check the auger to tractor mounting dimensions per the drawing prior to attaching. **See Fig. 3.** The auger is designed to be attached to a tractor during any operation including transporting, moving, raising, lowering or working.

Because the unit must operate throughout a wide range of geometry, each dimension must be within a specified range. Verify that these dimensions fall within the recommended ranges before attaching.

- a. Dimension A: Must be within 34 and 36 inches. This works with the length of the PTO shaft supplied with the auger to allow telescoping and prevent bottoming out.
- b. Dimension B: Must be within 6 to 10 inches. This will keep the angle of the universal joints equal and as small as possible. It also prevents bottoming out when the auger is raised.
- c. Dimension C: Must be between 14 to 16 inches. This will prevent the PTO shaft from bottoming out when the auger is raised and prevent separation when the auger is lowered. These dimensions are specified by Standards and most tractors comply. If your tractor does not comply, refer to your tractor manual and adjust to comply with these requirements.

7. Use the jack on the hitch to raise or lower the auger as required to match the draw-bar.

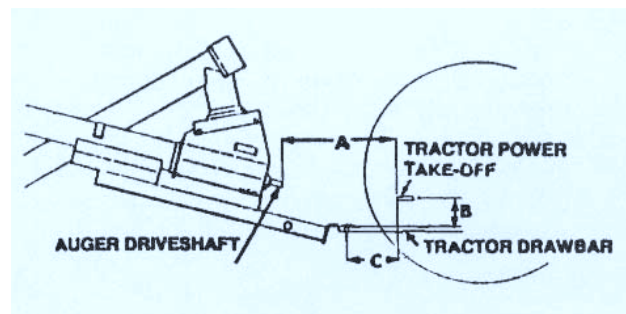

Fig. 3 ATTACHING DIMENSIONS

8. Use a 5/8 inch bolt as a pin. Use large flat washers above and below the hitch and a nut and jam nut on the bolt. Do not tighten to draw-bar but jam the nuts together to hold. A bolt will allow free hitch movement while the Auger is being raised or lowered. **See Fig. 4.**

9. Attach the safety chains to the draw-bar cage.



Fig. 4 ATTACHED

10. Attach the PTO shaft:

- a. Clean the splines on the shaft and in the yoke if required.
- b. Check that the guard rotates freely and the drive-line telescopes easily. If not clean, lubricate or repair as required before installing.
- c. Retract collar on yoke and slide the yoke over the tractor shaft. Stop when the lock pin clicks into position in the groove.
- d. Pull on the yoke to make sure it is locked to the shaft.**

IMPORTANT !

Never attach to tractor that is equipped with a PTO shaft adapter. It will change the required machine attaching dimensions and can lead to over speeding. Use only a tractor equipped with a 6 spline 540 RPM PTO shaft.

11. Attach the hydraulic lines:

- a. Use a clean rag or paper towel to clean dirt from around the couplers on the hose ends and on the tractor.
- b. Connect the hoses to the tractor couplers. Be sure the couplers are securely seated.

c. Route the hoses to prevent pinching rubbing or binding and allow enough slack for raising and lowering. Keep the hoses away from moving parts.

12. Open the valve in the hydraulic circuit to allow oil to flow to the cylinder for lowering or raising if required.



DANGER

**Stay away from overhead power-lines.
Electrocution can occur without direct contact.**

13. Raise and pin swing auger if moving.

14. Unpin and lower swing auger if preparing to work.

15. Lower hitch and stow the jack into its horizontal position.

16. To level hopper with ground adjust screw jack on hitch. See **Fig. 5**.

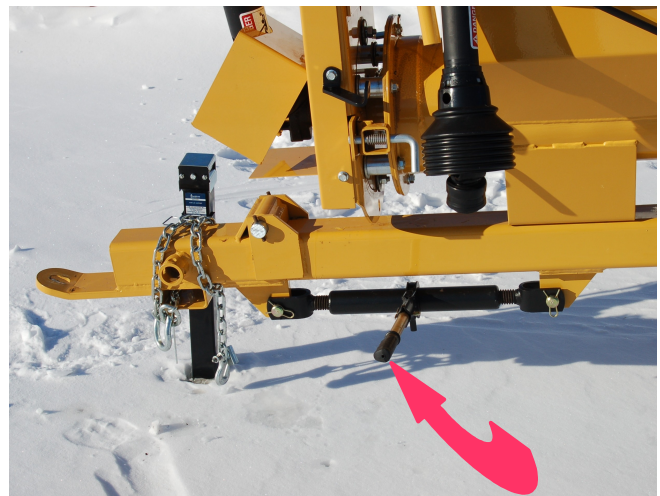

Fig. 5 SCREW JACK

17. Reverse the above procedure when unhooking.

4.6 MACHINE PLACEMENT

Follow this procedure when placing the auger into its working position:

1. Clear the area of bystanders, especially small children, before starting.
2. Be sure there is enough clearance from overhead obstructions and power lines or other equipment to move the Auger into its working position.
3. Attach the Auger to the tractor (See Section 4.5).
4. Open the valve in the hydraulic circuit.
5. Back the Auger up to the storage facility while it is in its lowered configuration. See Fig. 6
6. Remove the swing auger transport rod and stow on the support arm bracket. Install the retaining pins through the rod. See Fig. 7



Fig. 6 ALIGN AUGER WHILE IN LOWERED POSITION

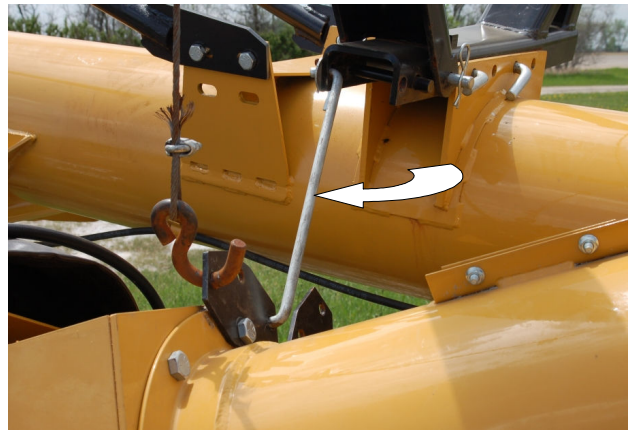

Fig. 7 TRANSPORT ROD

7. Use the tractor hydraulics to slowly raise the outlet end into position. Stay away from power lines. See Fig. 8



DANGER

Stay away from overhead power-lines. Electrocutation can occur without direct contact.

8. Slowly back the Auger until the outlet is over the opening in the storage facility. Leave the hitch attached to the tractor.



Fig. 8 RAISING

9. Slowly lower the outlet end until it is resting on the storage facility. Leave the hitch attached to the tractor.

10. Place chocks in the front and rear of each Auger and tractor wheel.

Note: Steps 11 through 14 with figures 9 and 10 below apply to older models . Pages 28 and 29 give some additional information on these older models.

11. Remove vertical drive-line from transport holder.

12. Retract the lock pin holding the chain drive in the vertical position and rotate the assembly 90 degrees. Place the gearbox on the side opposite to where the swing auger will be located. Secure the lock pin on both sides.

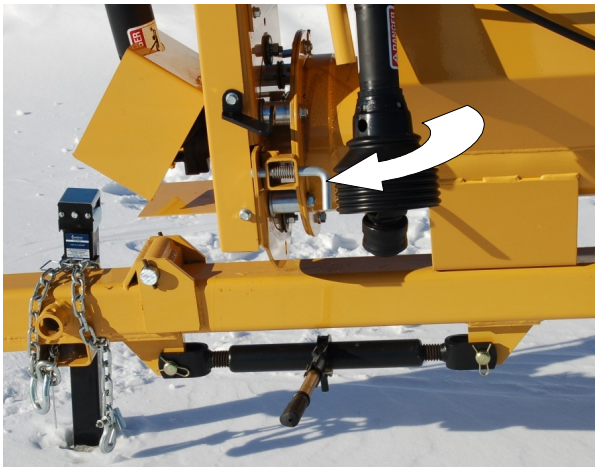

Fig. 9 LOCK PIN

13. Place the tubular plastic guard over the gearbox shaft that will not be used and tighten hose clamp.

14. Attach the vertical drive-line to the gearbox.



WARNING

Do not use bolts or square headed set screws in the yoke. They project from the yoke and create a safety hazard.

15. Lower the swing auger to the ground and unhook the cable.

16. Close the valve in hydraulic circuit.



Fig. 10 VERTICAL DRIVELINE



Fig. 11 RAISED POSITION

4.7 OPERATING

When using the Auger, follow this procedure:

1. Clear the area of bystanders especially small children, before starting.

2. Review the Pre-Operation Checklist (Section 4.4) before starting.

3. Review the Workplace Hazard Area drawing and use extra care when inside the hazard area. See Fig. 11. Keep all spectators and bystanders out of this area. Should anyone enter this area, stop the machine immediately.

4. Check that the machine is placed per Section 4.6.

5. Back a tractor up to the inlet end and attach with a bolt, washers and double nuts. Attach the PTO driveline. Align the tractor axis with the Auger so the universal joints are equal and as small as possible. Place chocks next to tractor tires and set the park brake.

6. Check that the driveline out of the gearbox is secured to the output shaft.

7. Check that all guards are in place and working as intended.

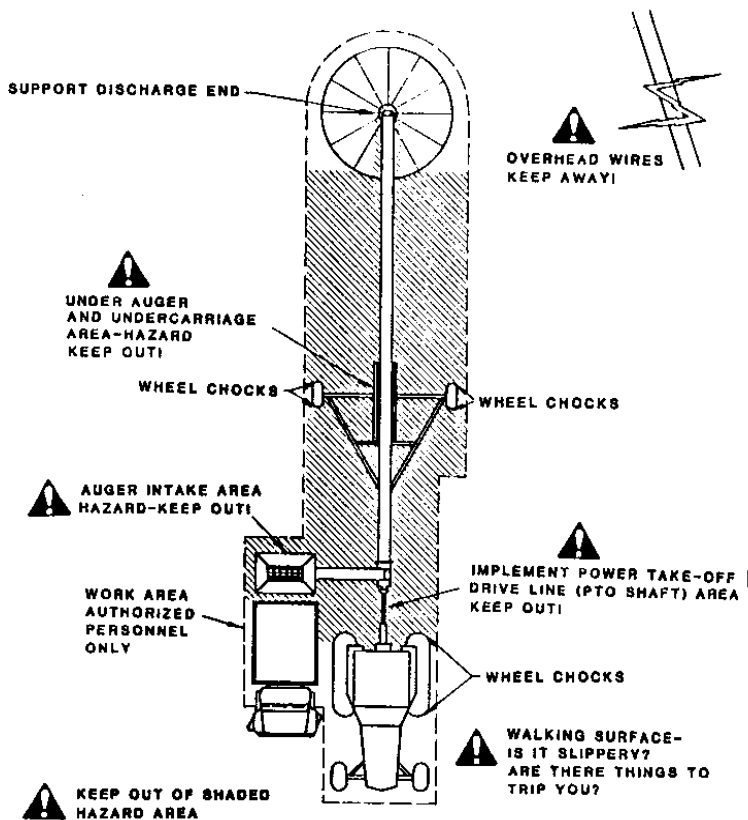

Fig. 12 WORKPLACE HAZARD AREA

8. Move the swing hopper out of the way. Normally this will be up against the frame.

9. Drive or back the truck into position for unloading.

10. Use the handle on the hopper to move the swing auger into position under the truck. See **Fig. 13**.

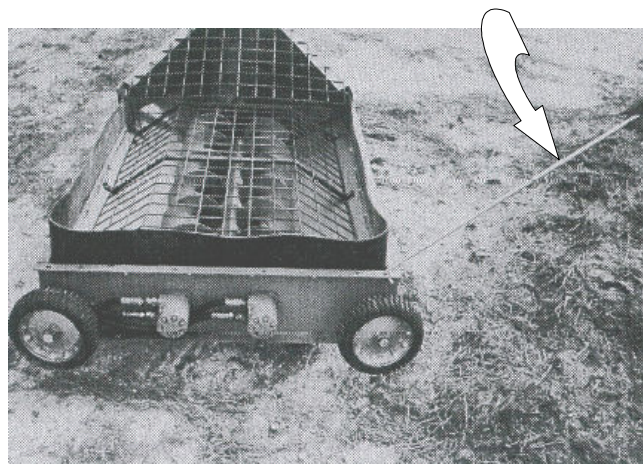

Fig. 13 Swinging Out

11. Starting:

a. Start the tractor engine and run at low idle.

b. Engage the PTO clutch.

c. Activate the circuit to the motor if equipped with the hydraulic drive option.

d. Increase engine speed to 500 RPM PTO speed.

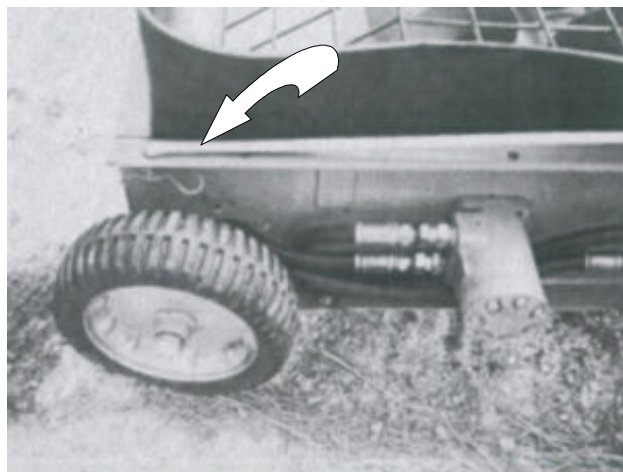

Fig. 14 Store Handle

12. Start the flow or grain and unload.

13. When the truck is unloaded and PTO is shut off, move the swing hopper out of the way and store the handle. See **Fig. 14**.

SWING AWAY HOPPER

14. Stopping:

- Run the auger until the swing hopper is empty.
- Slow the engine speed to low idle.
- Disengage PTO clutch.
- Shut off hydraulic motor if so equipped.
- Stop engine and remove ignition

15. Operating Hints:

- Run the unit at approximately 500 RPM to obtain the most consistent results.
- Always listen for any unusual sounds or noises. If any are heard, stop the machine and determine the source. Correct the problem before resuming work.
- Never allow anyone into the workplace hazard area. If anyone enters, stop immediately. Make them go before resuming work.
- Do not run the machine for long periods of time with no grain in the tube. It is noisy and increases the wear. Try to run only when moving grain.
- Do not move the machine by hand, Always use a tractor.
- Always locate the swing hopper within 20 degrees of a right angle to the main tube for optimum performance. See Fig. 15.
- When the auger is used to put grain in a pile, the grain can build up and cover the wheels. It is recommended that the operator attach a log chain to each axle when the auger is positioned. Before pulling the auger out of the pile, pull the chains tight and attach to the drawbar. This will prevent axle or frame bending.

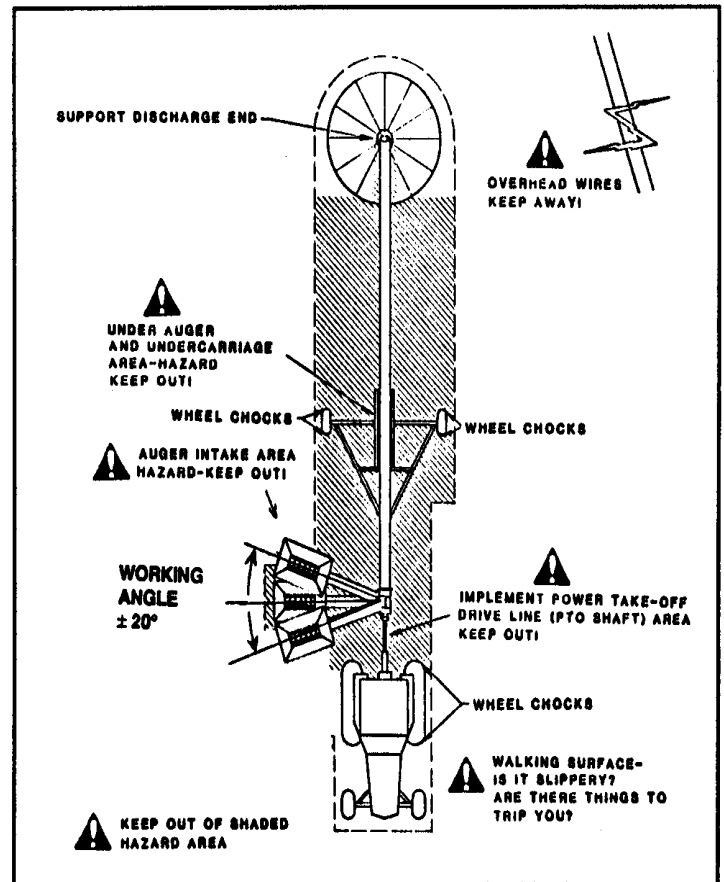

Fig. 15 SWING AWAY HOPPER POSITION

4.8 TRANSPORTING SAFETY



1. Read and understand ALL the information in the Operator's Manual regarding procedures and SAFETY when moving or transporting the Auger.
2. Check with local authorities regarding Auger transport on public roads. Obey all applicable laws and regulations.
3. Always travel at a safe speed. Use caution when making corners or meeting traffic.
4. Make sure the SMV (Slow Moving Vehicle) emblem and all the lights and reflectors that are required by the local highway and transport authorities are in place, are clean and can be seen clearly by all overtaking and oncoming traffic.
5. Do not allow riders on the Auger or the tractor when transporting.
 6. Attach Auger to towing vehicle with a bolt, washer and double nut. Always attach the safety chain.
7. Lower Auger to its lowest position for transporting.
8. Keep to the right and yield the right-of-way to allow faster traffic to pass. Drive on the road shoulder, if permitted by law and the roadway is firm enough to support the load.
9. Do not exceed 20 mph (32 km/h). Reduce speed on rough roads and surfaces.
10. Stay away from overhead obstructions and power lines when transporting. Electrocutation can occur without direct contact.
11. Always use hazard warning flashers on tractor when transporting unless prohibited by law.

Important Transport Instructions!

Theyenne/Westgo Portable Augers are designed to be easily and conveniently moved from place to place. When transporting, follow this procedure:

1. Be sure all bystanders are clear of the machine.
2. Attach loosely to the tractor using a bolt with washers, double nuts and the safety chain. **See Fig. 16.** The double nuts need to be tight against each other. The loosely word applies to some room in the auger hitch, the drawbar and vertical space for the attachment to move through an arc pattern as the auger is raised or lowered.
3. **Special Transport Precaution!** The heavy duty tractor PTO **will** suffer damage when moderately sharp turns are made. Turning while backing puts the PTO at particular risk. Uncouple the tractor PTO and support it while in transport.



Fig. 16 HITCH

4. Before raising the auger and/or moving the hopper out!

- a. Be careful not to allow binding or twisting of the hopper and inclined tube to occur while doing either or both of these functions. Current 13" inch models have the drive inside the inclined spout which reduces the potential for damage. See small picture to the right.



4. (continued)

b. On older models with three position gear boxes. Pull pin at bottom of telescopic tube, uncouple telescopic tube, uncouple PTO shaft, and rotate gear box pivot into the 12 O'clock position. Failure to do these steps will result in damage.



c. On older models with dual mounted gear boxes. Pull pin at bottom of telescopic tube and uncouple the vertical PTO shaft. Failure to do these steps will result in damage.

5. Use the winch to raise the swing auger or hopper off the ground. Attach the hook so the wire mesh and rubber belt are against the main tube.

6. Raise until the cable clamp contacts the support arm. See Fig. 17.



Fig. 17 CABLE CLAMP

7. Raise the swing auger further until the support is against its stop and the hopper is against the main tube.

8. Install the swing hopper transport rod and its retainers. See Fig. 18.

9. Place the hitch jack into its transport position.

10. Attach the hydraulic line, open the valve and lower the machine if required. Transport only when auger is in its lowest position.

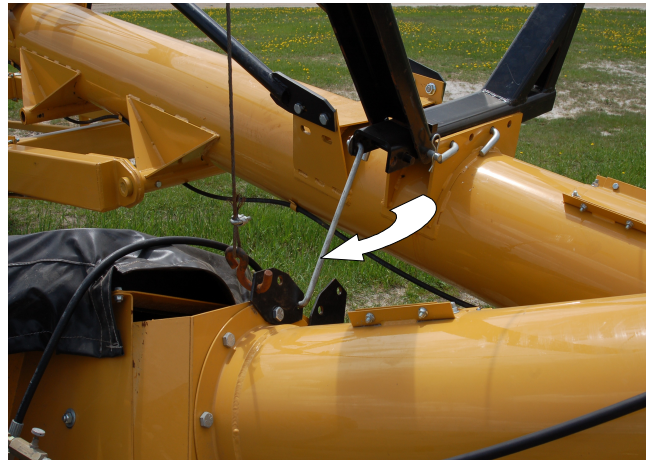

Fig. 18 FULLY RAISED HOPPER



11. Stay away from overhead power lines.

DANGER

Stay away from overhead power-lines. Electrocutation can occur without direct contact.

12. Never go across slopes of more than 20 degrees. It is better to go straight up or straight down.

13. Keep to the right and yield the right-of-way to allow faster traffic to pass. Drive on the road shoulder, if permitted by law.

14. Make sure the SMV (Slow Moving Vehicle) emblem and all the lights and reflectors that are required by the local highway and transport authorities are in place, are clean and can be seen clearly by all overtaking and oncoming traffic.

15. It is not recommended that the machine be transported faster than 20 mph (30 km/h). **Table 1** gives the acceptable transport speed as the ratio of tractor weight to Auger weight.

16. Do not allow riders on the machine or tractor.

17. During periods of limited visibility, use pilot vehicles or add extra lights to the machine.

18. Always use hazard flashers on the tractor when transporting unless prohibited by law.

Table 1 Speed vs Weight Ratio

<u>Road Speed</u>	<u>Weight of fully equipped or loaded implement(s) relative to weight of towing machine</u>
Up to 32 km/h (20 mph)	1 to 1, or less
Up to 16 km/h (10 mph)	2 to 1, or less
Do not tow	More than 2 to 1

4.9 STORAGE

 STORAGE SAFETY
1. Store the unit in an area away from human activity.
2. Do not permit children to play on or around the stored machine.
3. Lower Auger to its lowest position for storage unless placed in its operating position.

After the season's use, the machine should be thoroughly inspected and prepared for storage. Repair or replace any worn or damaged components to prevent any unnecessary down time at the start of the next season. To insure a long, trouble free life, this procedure should be followed when preparing the unit for storage each year:

1. Wash the entire machine thoroughly using a water hose or pressure washer to remove all dirt, mud, debris or residue.
2. Inspect all moving or rotating parts to see if anything has become entangled in them. Remove the entangled material.
3. Lubricate all grease fittings to remove any moisture in the bearings.
4. Run the machine slowly for 1 minute to distribute lubricant to all surfaces.
5. Apply a light coat of oil to the roller chain while the unit is running to prevent rusting.
6. Inspect all hydraulic hoses, fittings, lines, couplers and valves. Tighten any loose fittings. Replace any hose that is badly cut, nicked or abraded or is separating from the crimped end of the fitting.
7. Touch up all paint nicks and scratches to prevent rusting.

8. Select an area that is dry, level and free of debris. Protection from wind is usually a good thing. However; for those in northern climates, storage areas where deep snow drifts occur should be avoided. Auger frames can be bent when snow drifts settle and melt in the spring.

9. If the auger is not being left in a storage facility, it should be placed in its **lowest position**.

10. It is recommended that the swing auger hopper be lowered to rest on the ground for long term storage. This will release the twisting load on the frame from the swing auger support frame.

11. Follow the procedure given in Section 4.6 when unhooking.

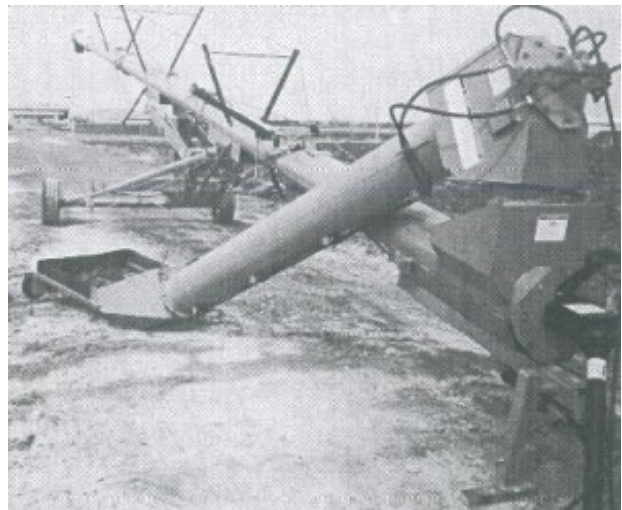

Fig. 19 STORAGE

5 MAINTENANCE AND SERVICE



MAINTENANCE SAFETY

1. Review the Operator's Manual and all safety items before working with, maintaining or operating the Auger.
2. Stop the engine, place all controls in neutral set park brake, remove ignition key and wait for all moving parts to stop before servicing, adjusting, repairing or unplugging.
3. Wear appropriate protective gear. This list includes but is not limited to:
 - A hard hat
 - Protective shoes with slip resistant soles
 - Protective goggles
 - Heavy gloves
 - Hearing protection
 - Respirator or filter mask
4. Before applying pressure to a hydraulic system, make sure all components are tight and that hoses and couplings are in good condition.
5. Relieve pressure from hydraulic circuit before servicing or disconnecting from tractor.
6. Keep hands, feet, hair and clothing away from all moving and/or rotating parts.
7. Clear the area of bystanders, especially children, when carrying out any maintenance and repairs or making adjustments.
8. Place stands or blocks under the frame before working beneath the machine.
9. Before resuming work, install and secure all guards when maintenance work is completed.

5.1 SERVICE

5.1.1 FLUIDS AND LUBRICANTS

1. Grease

Use an SAE multi-purpose high temperature grease with extreme pressure (EP) performance. Also acceptable is an SAE multi-purpose lithium based grease.

2. Lubricating oil

Use a standard automotive oil for all requirements.

3. Gearbox oil

Use an SAE 85W90 gear oil for all operating conditions.

Gearbox Capacity: 1 U.S. quart (0.85 liter)

4. Storing Lubricants

Your machine can operate at top efficiency only if clean lubricants are used. Use clean container to handle all lubricants. Store them in an area protected from dust, moisture and other contaminants.

5.1.2 GREASING

Use the Maintenance Checklist provided to keep a record of all scheduled maintenance.

1. Use a hand-held grease gun for all greasing.

2. Wipe grease fitting with a clean cloth before greasing, to avoid injecting dirt and grit.

3. Replace and repair broken fittings immediately.

4. If fittings will not take grease, remove and clean thoroughly. Also clean lubricant passageway. Replace fitting if necessary.

5.1.3 SERVICING INTERVALS

8 HOURS OR DAILY

1. Grease PTO shaft (4 locations).
See Fig 20.

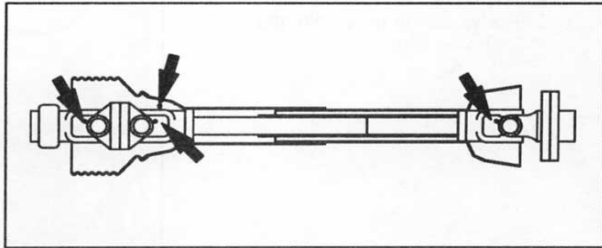

Fig. 20 PTO SHAFT (HORIZONTAL SHAFT)

2. Grease vertical drive shaft (3 locations).
See Fig 21.



Fig. 21 DRIVE SHAFT (VERTICAL SHAFT)

40 HOURS OR MINIMUM OF ANNUALLY

1. Grease bearings on both drive shafts.
See Fig. 22.

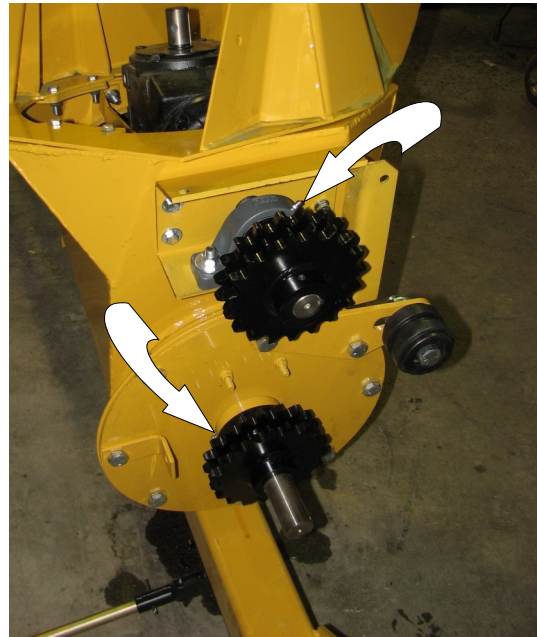

Fig. 22 BOTTOM BEARINGS

5.1.3 SERVICING INTERVALS Cont.

40 HOURS OR ANNUALLY Cont.

3. Grease top bearing. See Fig. 23.



Fig. 23 TOP BEARING

200 HOURS OR ANNUALLY

1. Repack wheel bearings.



ANNUALLY

1. Check oil level in gearboxes

5.1.4 SERVICE RECORD

See Lubrication and Maintenance sections for details of service. Copy this page to continue record.

ACTION CODE: ✓ CHECK CL CLEAN
 L LUBRICATE R REPACK

MAINTENANCE	HOURS													
	SERVICED BY													
8 Hours or Daily														
L PTO Shaft (3)														
L Drive Shaft (4)														
L Chain Drive Sprocket Bearing														
✓ Gearbox oil levels (2)														
40 Hours or Weekly														
L Roller Chain														
200 Hours or Annually														
R Wheel Bearings (2)														
CL Gearbox Breathers														

5.2 MAINTENANCE

By following a careful service and maintenance program for your machine, you will enjoy many years of trouble free-service.

5.2.1 SHEAR PIN - Fig. 24

The input driveline is equipped with a shear pin to protect against overloads.

To replace pins, follow this procedure:

1. Stop engine and remove ignition key.
2. Remove the pin parts remaining in the yoke.
3. Install a new pin using genuine Sheyenne/Westgo parts and tighten.

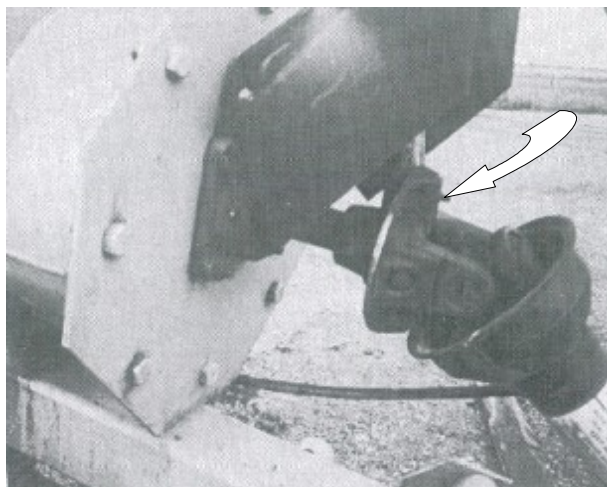

Fig. 24 SHEAR PIN

5.2.2 CLEAN-OUT DOOR - Fig. 25

A small clean-out door is located on the bottom of the tube at the lower end. Clean the tube by opening this door. Stop engine and remove PTO driveline before opening door.

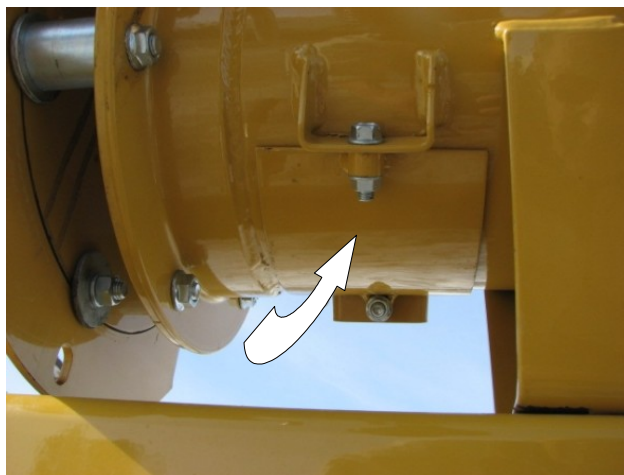

Fig. 25 CLEAN-OUT DOOR

5.2.3 TRUSS CABLES - Fig. 26

Adjust the cable anchor, eye bolts to align the auger tube. Be sure to re-tighten the jam nut on the eye bolt when adjustment is complete.

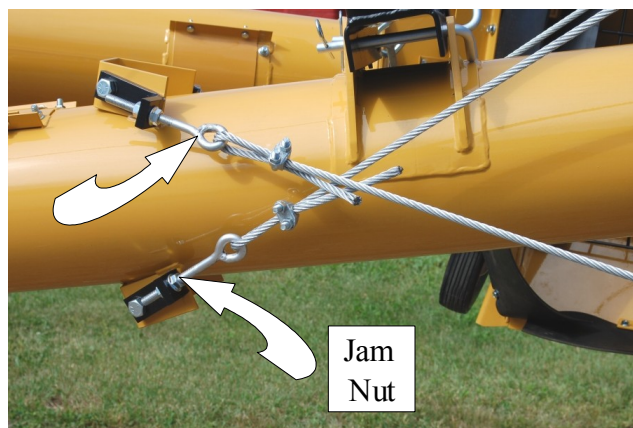

Fig. 26 CABLE ANCHOR, EYE BOLTS

5.2 MAINTENANCE Cont.

5.2.4 SWING AUGER BEARING REPLACEMENT - Fig. 27

An access cover is located on the swing auger to allow bearing replacement. Stop engine and remove ignition key or remove the PTO drive-line before opening access cover. Install and secure the cover before resuming work.

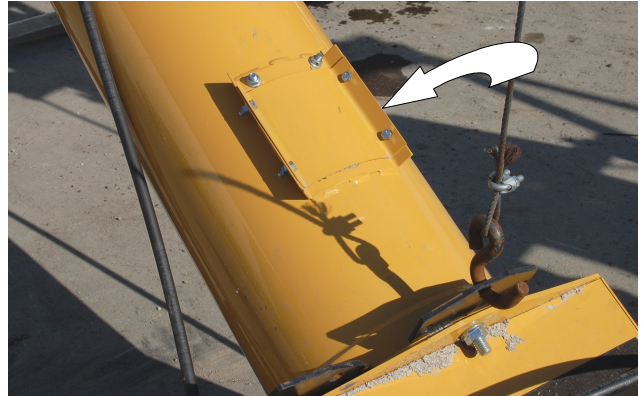

Fig. 27 ACCESS COVER

5.2.5 SWING AUGER AND HOPPER SUPPORT - Fig. 28

The winch and support frame for lifting and holding the swing auger and hopper can be mounted on either side of the machine.

Remove and mount to the opposite side if required. Remove the mounting pins for each component when moving. Install the retainers in the pins before raising the swing auger.



Fig. 28 SWING AUGER SUPPORT

5.2.6 Double Constant Velocity Joint

Instructions for Replacing the Double Constant Velocity Joint

1. Check that the support cross rod is properly adjusted. The rod should be tightened so dimension "B" is equal to dimension "A". See figure 29.

2. Remove the safety mesh. Note: After installing the constant velocity (CV) joint, it is important that the safety mesh be reinstalled (only remove for installation). The mesh provides required structural support to the hopper. Remove the 5/16 bolts that hold the CV joint to the helicoids. (Models prior to 1997 may have a flex shaft. Flex shafts are no longer available.) Do not use a hammer to remove bolts; the helicoids will bend causing vibration.

3. Remove hopper from inclined tube assembly.

4. Grease the inside end of the hopper helicoid; insert the hex connector so the holes align. Guide a 5/16 x 2 bolt through the hole in the hopper helicoid and tighten with a locknut.

5. Bolt tube connector to CV joint using 5/16 x 2 1/2 bolt and lock nut.

6. Grease inside end of inclined tube helicoid; insert end of tube connector into the helicoid. Fasten with 1/16 x 2 bolt and locknut. Do not tighten until final adjustment (see step 8).

7. Guide the incline tube on to the hopper, the angle ring spacer (use only for augers sold prior to 1994) held in between them. At the same time, the CV joint must be guided onto the hex connector, only guide the CV joint on to the hex connector where the helicoids will not interfere with each other (rotate the hopper helicoid to the desire position).

Where the end of the hopper flighting ends, the inclined tube flighting should begin. Use 1/2 x 2 1/2 bolts for a 10" auger and 7/16 x 2 1/2 bolts for an 8" auger to assemble the hopper to the inclined tube.

8. Adjust CV joint so that it is approximately 1/4" from bottoming out on the hex connector. Tighten locknut at inclined tube connection.

9. Slowly rotate the hopper helicoid and visually check that the flighting ends are at least 1/4" away from the CV joint in all positions. Torch flighting to remove any interfering material. Be careful not to cut the CV joint or connectors.

10. REMEMBER TO RE-INSTALL THE SAFETY MESH. THIS IS VERY IMPORTANT.

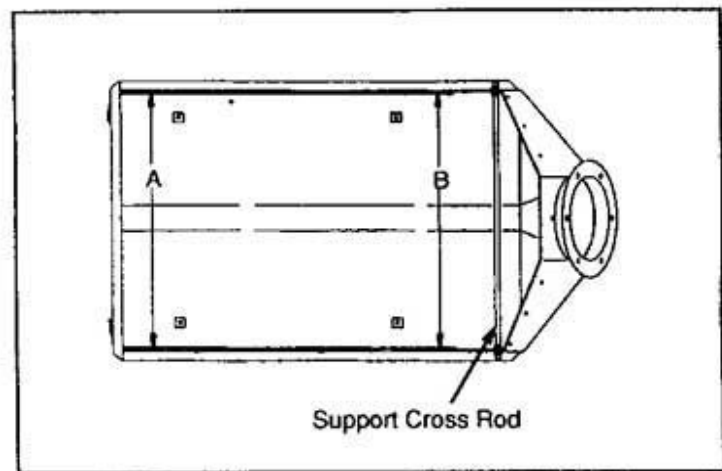

Fig. 29 HOPPER

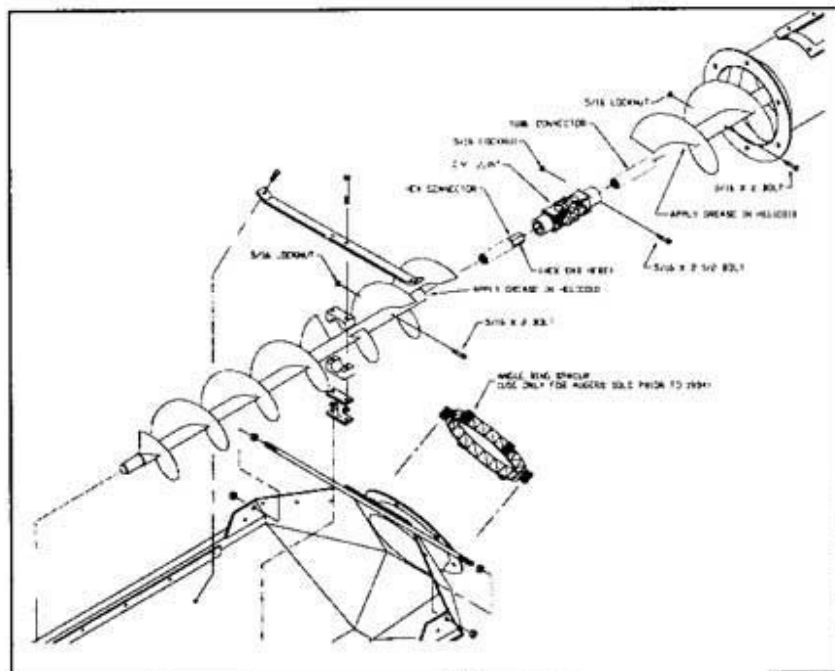

Fig. 30 DOUBLE CONSTANT VELOCITY JOINT

5.2.7 CURRENT MODEL HOPPER U-JOINTS

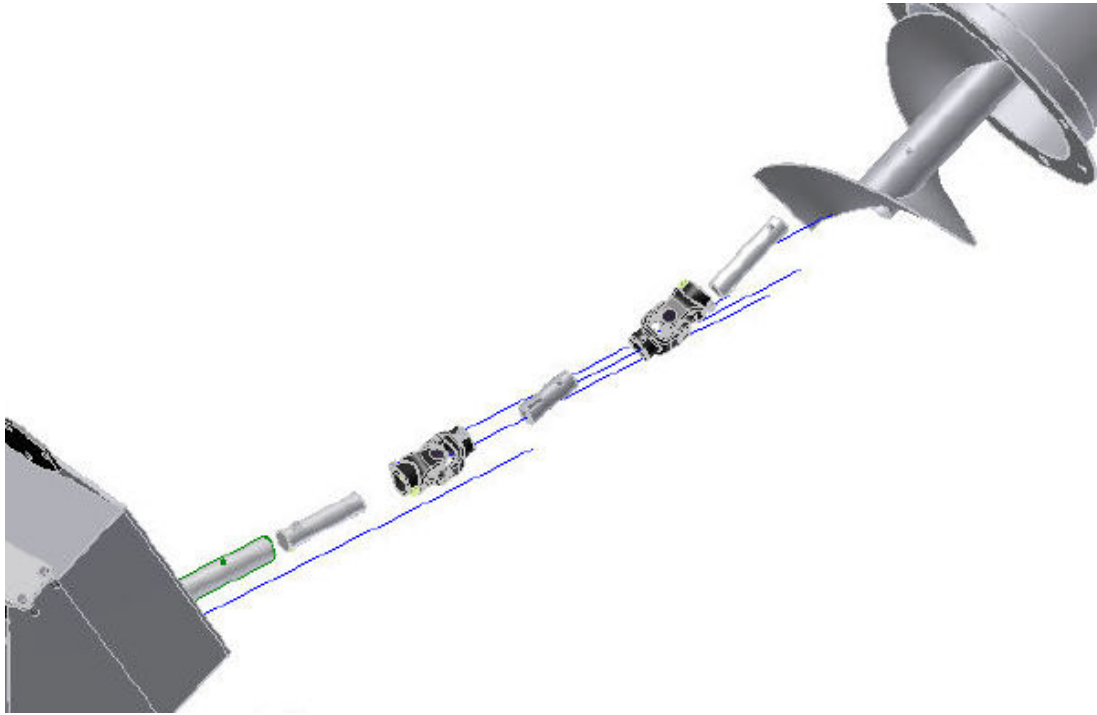

Fig. 30b Two U-Joint Hopper Drive

Figure 30b above shows the proper assembly sequence and orientation of parts to connect the inclined auger helicoid to the drive shaft in the hopper.

To replace any of these parts you should follow the steps for the double CV joint on the previous page (38). The part descriptions and part numbers are different, but the steps are the same.

6 TIMING THE FLIGHTING

6.1 HANGER BEARINGS, 1410 AUGER

On the 1410 augers the flighting is supported by hanger bearings every 10 feet (3 m). Although they do not require lubrication, they can fail after extended periods of use. Normally failure will be accompanied by an increase in noise level. Access covers on the top of the tubing allow access for bearing replacement.

To replace bearing, follow this procedure:

1. Clear the area of bystanders, especially small children.
2. Remove power as appropriate:
 - a. Disconnect PTO shaft from tractor.
 - b. Turn electric motor OFF and lock out power at master panel.
3. Remove access cover next to failed bearing and the access covers the rest of the way down the auger. **See Fig. 31.**
4. Remove bolts from the hanger bearings next to the access cover holes.
5. Remove intake bearing assembly from the bottom of the auger.
6. Replace the hanger bearing that has failed. **See Fig. 32. Use only genuine Sheyenne/Westgo replacement parts.**

IMPORTANT TIMING INFORMATION!

7. Slide flighting sections and bearing assemblies back into tube. The hex shafts and the flighting sockets to which they mate **“time”** the flighting. To do justice to this very important topic we direct you to page 42.



**Fig. 31 BEARING REPLACEMENT
(Access Covers)**

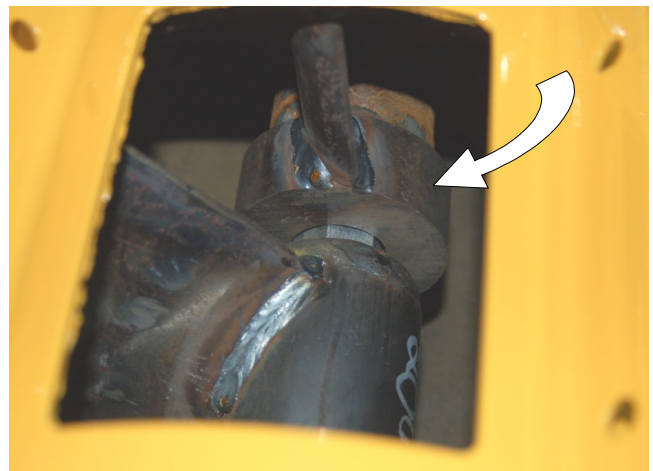

**Fig. 32 BEARING REPLACEMENT
(Hanger Bearing)**

CORRECT TIMING

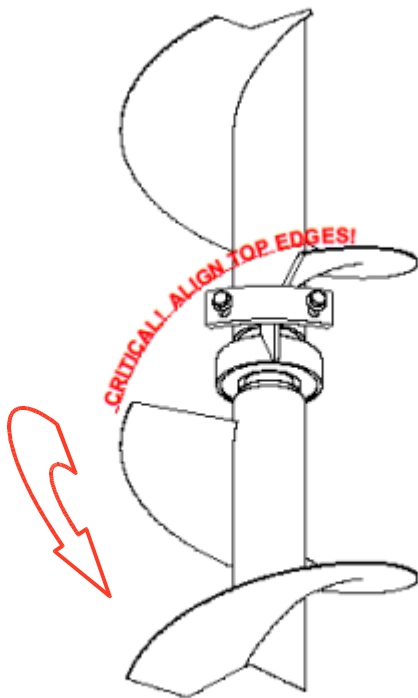

Fig. 33

The hex connecting shafts that engage adjacent flightings allow only six assembly options. Move the lower section all the way up to the hanger bearing and observe the alignment. It is likely that you will not be able to achieve the perfect “flow” shown above. If not, slide the section of flighting back down the tube enough to clear the hex shaft and rotate the outer edge left and down (as indicated by the arrow) until you can engage the next hex shaft corner. Move the flighting section back up to the hanger bearing and check again. If you have to be “advanced” a few degrees, that's OK.

We at Sheyenne/Westgo think it is worth your while to open all access covers and check for proper assembly. The auger capacity and life of the flighting are significantly affected.

INCORRECT TIMING

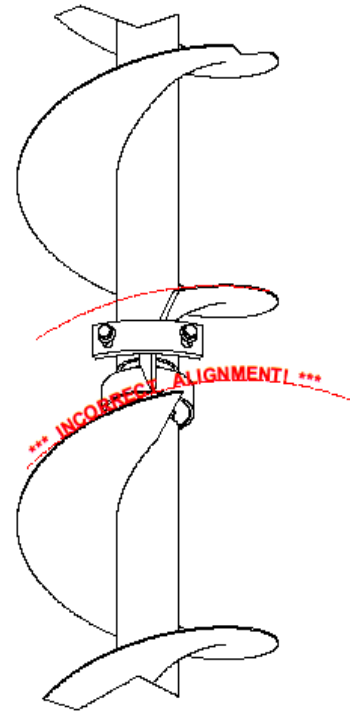

Fig. 34

When flighting sections are assembled as shown here, grain is brought up from below and “packed” in behind the next flighting section. Again, this reduces capacity and increases flighting wear.

If you are the person assembling auger flighting sections and the above alignment happens, correct it. If you open access covers and find this, correct it.

8. With all sections properly timed, reinstall access covers and tighten mounting bolts to their specified torque.

7 TROUBLE SHOOTING

The Sheyenne/Westgo Portable Auger uses rotating flighting to move grain. It is a simple and reliable system that requires minimal maintenance.

In the following section, we have listed many of the problems, causes and solutions to the problems that you may encounter.

If you encounter a problem that is difficult to solve, even after having read through this trouble shooting section, please call your local Sheyenne/Westgo dealer. Before you call, please have this Operator's Manual and the serial number from your machine ready.

PROBLEM	CAUSE	SOLUTION
Auger doesn't turn	Broken shear pin	Replace shear pin
Poor capacity	Flighting sections not timed properly. (1410 Augers)	Open access covers and check alignment. If incorrect, disassemble and correct per pages 40 and 41.
	Incorrect PTO speed	This auger should operate at 500 RPM. (Over speeding will reduce capacity as much as under speeding).
	Improper Feeding	Intake end should be completely covered with grain
	Worn flighting at intake end	Replace flighting
Auger will not raise	Lift needle valve closed	Open lift needle valve
	Restrictions in hydraulic line	Check hydraulic line for restriction. (This generally occurs at the restrictor valve located next to the hydraulic cylinder)
	Faulty quick couplers on tractor or auger	Replace quick couplers
Auger drops or settles after being positioned	Lift needle valve not closed	Close needle valve after positioning the auger.
	Tractor hydraulic valve faulty	Contact your tractor dealer.

8 SPECIFICATIONS

8.1 MECHANICAL

Feature	13” - Model 1410
Auger Tube	13 Inch Outside Diameter
Auger Tube Specifications	12-3/4 O.D. X 12 Ga Wall
Rim Size	15” - 5 Bolt
Tire Size, 60 & 70 Foot Models	9.5L -15
Tire Size, 80 Foot Model	11.5L -15
Tire Pressure	32 psi Max - (Verify w/ Tire Rating)
Reach Arm Tube	3-1/2” O.D. X 10 Gauge
Tread Width, Center to Center	112” Narrow / 142” Wide
Hydraulic Cylinder	4” x 36” Stroke
Swing Hopper Tire Size	10” O.D.
Hopper Size	38” x 60” with Single Auger
Hopper Transport Winch	2550# Lift Capacity, Brake Type
Weight - 60 Foot Model	4,013 Lbs
Weight - 70 Foot Model	4,816 Lbs
Weight - 80 Foot Model	5,516 Lbs
Capacity	7,000 to 10,000 Bu / Hr
Power Requirements	1.5 HP / Ft of Length, Recommended

Specifications subject to change without notice

8.2 DIMENSIONS

Length	Auger Angle	A	B	C
60 Foot	9 Degrees – (Transport / Storage)	22'	11'	13'
	30 Degrees	20'	31.5'	34.5'
	40 Degrees – (Fully Raised)	19'	41'	43.5'
70 Foot	9 Degrees – (Transport / Storage)	31.5'	12'	15'
	30 Degrees	29'	36.5'	39.5'
	40 Degrees – (Fully Raised)	26'	47'	50'
80 Foot	9 Degrees – (Transport / Storage)	41'	14'	16.5'
	30 Degrees	37'	42'	44'
	40 Degrees – (Fully Raised)	34'	54'	56.5'

Axle Width Choices: **Narrow for Transport = 10'** **Wide for All Other = 12'-6"**

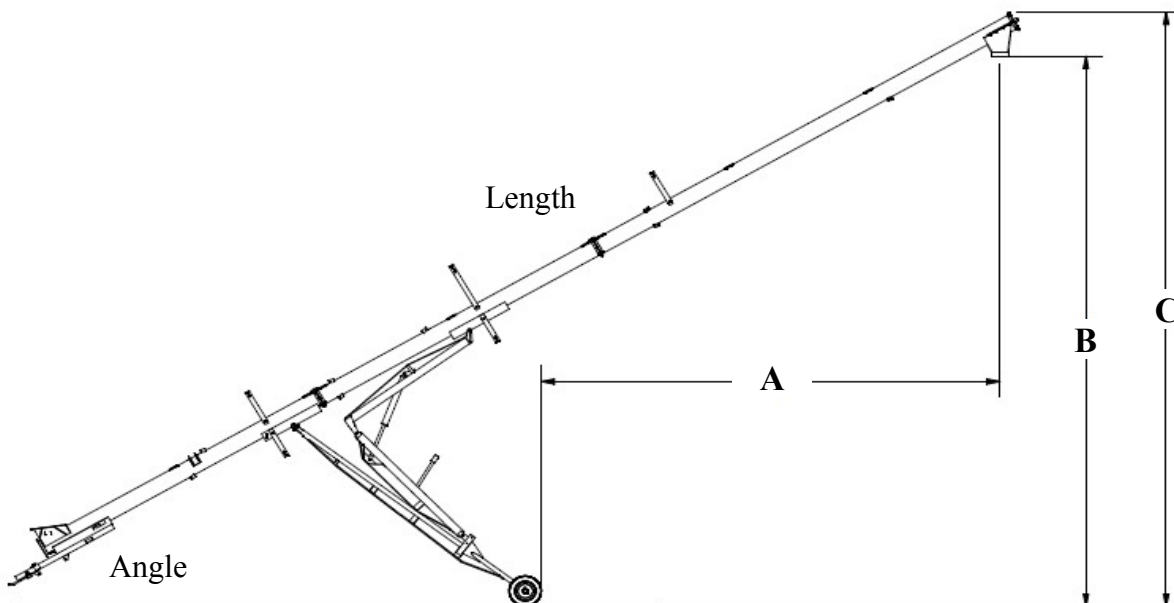

8.3 BOLT TORQUE

CHECKING BOLT TORQUE

The tables shown below give correct torque values for various bolts and capscrews. Tighten all bolts to the torques specified in chart unless otherwise noted. Check tightness of bolts periodically, using bolt torque chart as guide. Replace hardware with the same strength bolt.

ENGLISH TORQUE SPECIFICATIONS

Bolt Diameter "A"	Bolt Torque*					
	SAE 2		SAE 5		SAE 8	
	N.m	(lb-ft)	N.m	(lb-ft)	N.m	(lb-ft)
1/4"	8	(6)	12	(9)	17	(12)
5/16"	13	(10)	25	(19)	36	(27)
3/8"	27	(20)	45	(33)	63	(45)
7/16"	41	(30)	72	(53)	100	(75)
1/2"	61	(45)	110	(80)	155	(115)
9/16"	95	(70)	155	(115)	220	(165)
5/8"	128	(95)	215	(160)	305	(220)
3/4"	225	(165)	390	(290)	540	(400)
7/8"	230	(170)	570	(420)	880	(650)
1"	345	(225)	850	(630)	1320	(970)

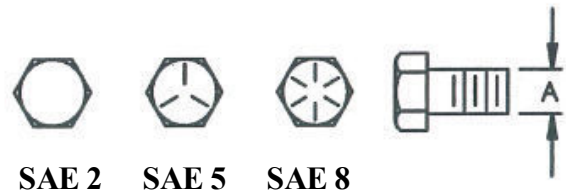

Torque figures indicated above are valid for non-greased or non-oiled threads and heads unless otherwise specified. Therefore, do not grease or oil bolts or capscrews unless specified in this manual. When using locking elements, increase torque values by 5%.

*Torque value for bolts and capscrews are identified by their head markings.

NOTES

This page for your use

PARTS & INDEX SECTION

TABLE OF CONTENTS

DESCRIPTION	PAGE
13 x 60 / Differences as compared to the 13 x 70	48
13 x 60, 70 & 80 Mechanical Drive - Exploded View	49
“ “ “ “ “ “ - Parts List	50
13 x 60, 70 & 80 Hopper and Inclined Tube - Exploded View	51
“ “ “ “ “ “ “ “ - Parts List	52
13 x 60 & 70 Transport, Lift Arm and Reach Arms – Exploded View	53
“ “ “ “ “ “ “ “ “ “ - Parts List	54
13 x 60 & 70 Tube, Helicoid, and Truss System – Exploded View	55
13 “ “ “ “ “ “ “ “ - Parts List	56
13 x 80 / Differences as compared to the 13 x 70	57
13 x 80 Transport, Lift Arms and Scissor Lift – Exploded View	58
13 x 80 “ “ “ “ “ “ - Parts List	59
13 x 80 Tubes, Helicoids and Rigid Trussing – Exploded View	60
13 x 80 “ “ “ “ “ - Parts List	61
Hopper Lift Arm (Effective date – May 2011)	61a
Tractor PTO Shaft Components	62
Hardware List	63
General Index	64 - 68

13 x 60 - Model 1410 - Mechanical Drive

For purposes of this owners manual and the lengthy process of exploding views of individual augers we are showing the 13 x 70 and identifying the differences of the 13 x 60 were applicable. These augers are large and contain many parts. To get reasonable size and clarity we have divided the auger into four sections, eight pages. See pages 49 through 56.

To be specific about the 13 x 60, it obviously is 10 feet shorter. It's tube sections are comprised of (2) thirty foot tubes v. (2) twenties and a thirty to total 70 for the one shown on page 55. The top or upper tubes are common. Helicoids are 10 foot in length; therefore the 60 foot auger will have one less helicoid section in it. Other differences will be noted in the table below. If you own a 60 foot auger you may wish to line out the (8) “70 foot part numbers” that are different, listed below and write in the 60 foot part numbers, quantities and lengths (highlighted yellow).

Pages 49 through 52 are common, 53 and 55 look alike. Differences in pages 54 and 56 are covered in the table below.

Page	Item	Qty	70' P/N		60' P/N		Description
54	6	1	100-2-1336		100-2-1308		Lower Lift Arm, Welded Assy
54	23	1	100-2-2692		100-2-2701		Upper Lift Arm, W/A
54	24	1	100-2-2903		100-2-2993		Reach Arm, LH - W/A
54	38	1	100-2-2904		100-2-2994		Reach Arm, RH – W/A
56	*	-	(6)100-2-2818	10'	(5) Same P/N	10'	Helicoid, 13” W/A (Total Qty)
56	26	1	100-2-2668	20'	-----	None	Intermediate Tube - W/A
56	50	1	100-2-3346	20'	100-2-3344	30'	Bottom Tube Weld
56	70	-	(2)100-3-2502	50'	(1)100-3-3628	36'	Truss Cable
56	71	1	100-3-3674	104'	100-3-3627	86'	Truss Cable, Long

* Page 56, exploded view shows three item numbers; 24, 28, and 36. They are common.

13" - Hitch & Drive

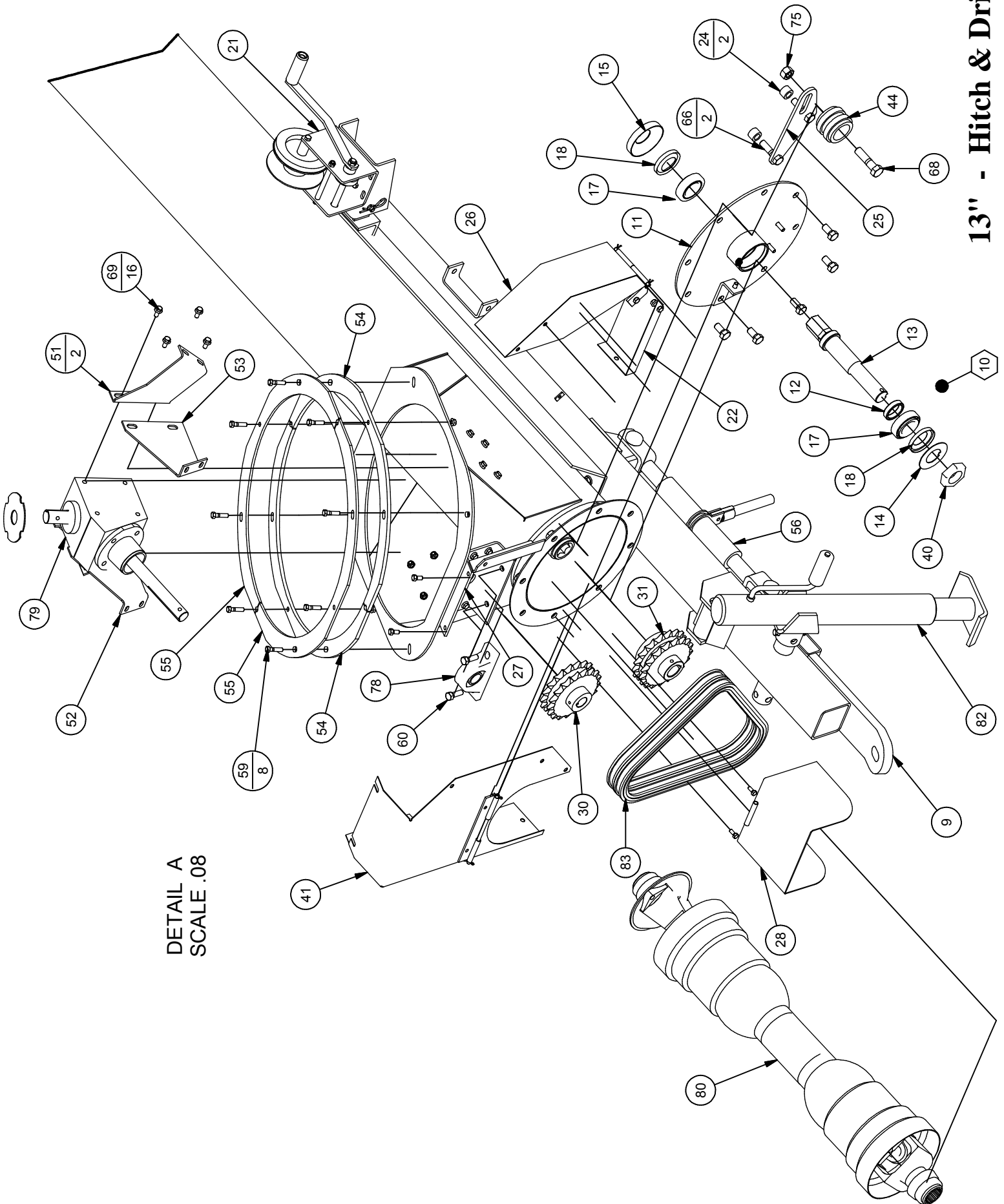

DETAIL A
SCALE .08

Parts List				Parts List			
ITEM	QTY	PART NUMBER	DESCRIPTION	ITEM	QTY	PART NUMBER	DESCRIPTION
1	2	100-2-1051	HUB ASSY., 5 BOLT	42	1	100-3-4826	MOUNT BRACKET
2	1	100-2-1295	TRANSPORT BRACE WELD	43	1	100-3-4831	STANDOFF BRACKET
3	1	100-2-1305	TUBE, REACH ARM	44	1	100-3-4838	80-2 IDLER
4	1	100-2-1336	LOWER LIFT ARM W/A	45	1	100-3-4841	HINGE PIN
5	1	100-2-2060	AXLE WELDMENT	46	1	100-3-4844	HINGE PIN
6	1	100-2-2657	TUBE, HITCH	47	1	100-3-5198	CYLINDER PIN
7	1	100-2-2692	UPPER LIFT ARM W/A	48	1	100-3-5198B	CYLINDER PIN
8	1	100-2-2801	13" MECHANICAL HOPPER ASSY.	49	1	100-3-5255	TRASH GUARD
9	1	100-2-2822	HITCH W/A, 13" FRONT	50	2	100-3-5258	HOPPER ARM MOUNTING PIN
10	1	100-2-2824	BEARING PLATE ASSY, 13"	51	2	100-3-5831	GEARBOX SIDE BRACKET
11	1	100-2-2760	BEARING PLATE WELD, 13"	52	1	100-3-5889	GEARBOX END BRACKET, RH
12	1	100-3-4278	COLLAR, TAPERED BEARING	53	1	100-3-5890	GEARBOX END BRACKET, LH
13	2	100-3-4282	1-1/2" HEX PTO DRIVE SHAFT	54	2	100-3-5896	PIVOT GUIDE PLATE
14	1	100-3-4283	CAP, LOCKING DUST	55	2	100-3-5897	HOLD-DOWN PLATE
15	1	100-3-4291	CAP, DUST	56	1	200-2-0705	RATCHET JACK
16	2	901-01301	BEARING CUP, # 25520	57	2	900-01055	5/16NC X 3/4 HEX BOLT G5
17	2	901-01311	TAPER BEARING AND CONE, 1.75" ID	58	8	900-01105	3/8-16 X 3/4 GR 5 HHCS
18	2	901-09220	SEAL # 22334TA	59	8	900-01113	3/8NC X 1-1/2 HEX BOLT G5
19	1	100-2-2903	REACH ARM, 70ft, LH	60	2	900-01225	1/2NC X 1-1/2 HEX BOLT G5
20	1	100-2-2904	REACH ARM, 70ft, RH	61	2	900-01247	1/2 X 4-1/2 HEX BOLT GR5
21	1	100-2-2925	WINCH BRKT. W/A 13"	62	4	900-01249	1/2-13 X 5 GR 5 HHCS ZP
22	1	100-2-3064	BOTTOM SHIELD WELDMENT	63	5	900-01339	5/8-11 X 1-1/4 GR 5 HHCS
23	1	100-2-3067	IDLER ADJUSTMENT WELDMENT	64	4	900-01341	5/8 NC X 1-1/2 HEX BOLT GR5
24	2	100-3-4820	SPACER TUBE	65	1	900-01343	5/8-11 X 1-3/4 GR 5 HHCS
25	1	100-3-4821	IDLER ADJUSTMENT ARM	66	2	900-01349	5/8-11 X 2-1/2 GR 5 HHCS
26	1	100-2-3069	CHAIN GUARD WELDMENT	67	4	900-01403	3/4NC X 2 HEX BOLT GR5
27	1	100-2-3077	SHIELD MOUNT WELDMENT	68	1	900-01411	3/4-10 X 3 GR 5 HHCS
28	1	100-2-3078	PTO SHIELD WELDMENT	69	16	900-03436	3/8 X 3/4 SERR FLANGE BOLT GR5
29	1	100-2-3079	HINGE WELDMENT	70	4	900-03438	3/8-16 x 1 SERR FLG BOLT
30	1	100-2-3126	SPROCKET 19T 80 1.25 BORE	71	20	900-06139	3/8 NC SERR FLANGE NUT
31	1	100-2-3128	DRIVE SPROCKET WELDMENT	72	20	900-06143	1/2 NC SERR FLANGE NUT
32	1	100-2-3131	HOPPER LIFT ARM WELD, 1510	73	12	900-06145	5/8NC SERR FLANGE NUT
33	1	100-2-3290	LIFT ARM MOUNT W/A, 13"	74	4	900-06147	3/4 - 10 FLANGE NUT
34	1	100-2-3511	14'10 13 X 70 TUBE & TRUSS ASSY.	75	1	900-06510	3/4 - 10 TOP LOCK HEX NUT
35	1	100-2-3575	PIVOT DRIVE ASSY., 13" M.D.	76	4	900-23023	COTTER PIN, 1/8 X 3/4
36	1	100-2-3576	INCLINE TUBE ASSY 13" MD	77	8	900-29220	3/8 X 1-3/4 ROLL PIN
37	4	100-3-0148	1/2 X 6 Eyebolt	78	1	901-01313	1-1/4 PILLOW BLOCK BRG
38	4	100-3-2400	PIN, HINGE	79	1	903-15634	GEARBOX, 668 - 112 DEG. 1:1
39	2	100-3-2454	U-BOLT, 1/2" NC 5 X 6 LG	80	1	903-18048	PTO SHAFT KIT, DBL CV JOINT
40	1	100-3-4287	1-3/4" - 12 NUT	81	2	905-21154	HYD. CYLINDER
41	1	100-3-4822	CHAIN GUARD	82	1	905-23024	5000# POLE JACK WELDMENT
				83	1	100-3-4933	# 80-2 X 50 PITCHES

13 x 60, 70 & 80 - Hitch & Drive Systems

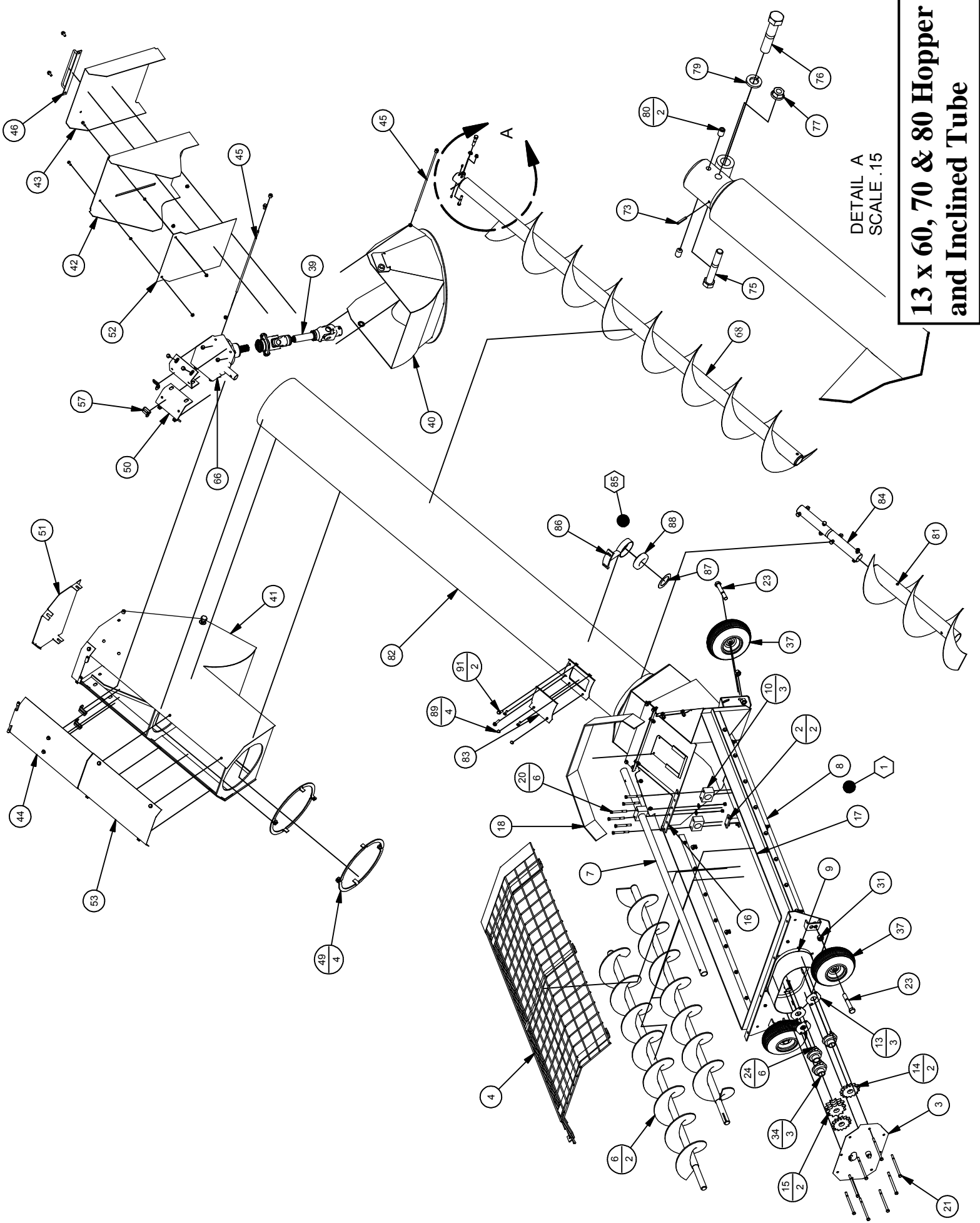

**13 x 60, 70 & 80 Hopper
and Inclined Tube**

Parts List				Parts List			
ITEM	QTY	PART NUMBER	DESCRIPTION	ITEM	QTY	PART NUMBER	DESCRIPTION
1	1	100-2-2801	13" MECHANICAL HOPPER ASSY.	48	2	100-3-5512	SPACER WASHER
2	2	100-2-2709	BAR, SPACER	49	4	100-3-5514	SPOUT TUBE CLAMP
3	1	100-2-2747	HOPPER, END PLATE W/A	50	2	100-3-5839	UPPER GEARBOX BRACKET
4	1	100-2-2798	MESH WELD, 13" SWIVEL HOPPER	51	1	100-3-5885	SPOUT END COVER
5	1	100-2-2800	HINGE WELDMENT, 13"	52	1	100-3-5873	PIVOT INSIDE SHIELD
6	2	100-2-2804	HOPPER HELICOID W/A	53	1	100-3-5874	INCLINE SPOUT COVER
7	1	100-2-2806	DRIVER SHAFT W/A	54	2	100-3-5882	PIVOT DOOR PIN CAP
8	1	100-2-2807	HOPPER WELD, 13" MECH	55	2	100-3-5887	HINGE PIN CAP
9	1	100-3-3510	GASKET, 8" HEAD COVER	56	2	100-3-5891	DOOR SLIDE BUSHING
10	3	100-3-3675	1-1/2 SPLIT WOOD BEARING	57	4	100-3-5899	SPRING MOUNT ANGLE
11	1	100-3-4109	TAB, LIFT HOPPER	58	2	900-01055	5/16NC X 3/4 HEX BOLT G5
12	1	100-3-4334	HINGE STOP, 13"	59	2	900-01407	3/4-10 X 2-1/2 GR 5 HHCS
13	3	100-3-4371	GASKET, 1-1/4" 2 HOLE	60	4	900-03419	5/16-18 X 3/4 SERR FLNG BOLT
14	2	100-3-4465	SPROCKET, 60B15 - 1.25B	61	14	900-03436	3/8 X 3/4 SERR FLANGE BOLT GR5
15	2	100-3-4468	SPROCKET, 60B11 - 1.25B	62	6	900-03438	3/8-16 x 1 SERR FLG BOLT
16	1	100-3-4942	MOUNT, SPLIT BRG-13"	63	6	900-06137	5/16 NC SERR FLANGE NUT
17	1	100-3-5340	RUBBER STRIP, 13" HOPPER	64	12	900-06139	3/8 NC SERR FLANGE NUT
18	1	100-3-5341	RUBBER STRIP, TOP	65	2	900-06510	3/4 - 10 TOP LOCK HEX NUT
19	4	900-01059	5/16NC X 1 HEX BOLT G5	66	1	903-15633	GEARBOX, 668 - 68 DEG. 1:1
20	6	900-01129	3/8NC X 3-1/2 HEX BOLT GR5	67	1	100-2-3576	INCLINE TUBE ASSY 13" MD
21	8	900-01141	3/8NC X 8 HEX BOLT GR5	68	1	100-2-3247	INCLINED HELICOID WELDMENT
22	2	900-01221	1/2NC X 1 HEX BOLT GR5	69	1	100-2-3248	TUBE WELDMENT
23	4	900-01423	3/4-10 X 5 GR 5 HHCS	70	1	100-2-3597	END COUPLER WELD, 13"
24	6	900-01694	3/8NC X 3/4 CARRIAGE BOLT	71	1	100-3-3292	TUBE
25	30	900-03438	3/8-16 x 1 SERR FLG BOLT	72	1	100-3-5886	COUPLER, NEW
26	6	900-03439	3/8NC X 1-1/4 SERR FLANGE BOLT	73	1	900-29082	1/8 X 3/4 ROLL PIN
27	4	900-06137	5/16 NC SERR FLANGE NUT	74	1	100-3-4487-88.94	5/16 SUPEREDGE FLIGHTING
28	36	900-06139	3/8 NC SERR FLANGE NUT	75	1	900-01121	3/8 NC X 2.5 HEX BOLT G5
29	12	900-06500	3/8 TOPLOCK NUT- UNC	76	1	900-01233	1/2-13 X 2-1/2 GR 5 HHCS ZP
30	2	900-06504	1/2" NC TOPLOCK NUT	77	1	900-06139	3/8 NC SERR FLANGE NUT
31	8	900-06510	3/4 - 10 TOP LOCK HEX NUT	78	1	900-06143	1/2 NC SERR FLANGE NUT
32	18	900-11033	3/8 USS FLATWASHER	79	1	900-11013	1/2" SPLIT LOCK WASHER
33	3	900-27024	1/4 X 1 WOODRUFF KEY #808	80	2	900-16361	5/16 NC X 1/2 SET SCREW CUP PT
34	3	901-01101	1-1/4 ECONOMOUNT BEARING	81	1	100-2-3364	INTAKE HELICOID, NEW
35	1	905-01159	HEX BUSHING, 1/2MPT X 1/8FPT	82	1	100-2-3577	INCLINED TUBE WELDMENT
36	1	905-03080	VENT PLUG, 1/8" NPT	83	1	100-3-1113	COVER, ACCESS 13"
37	4	905-09134	TIRE ASSY, HOPPER	84	1	100-3-4000	CONNECTOR SHAFT
38	1	100-2-3575	PIVOT DRIVE ASSY., 13" M.D.	85	1	106-2-0711	13" HANGER BEARING ASSY
39	1	100-2-3336	MECH. DRIVE LINE ASSY., 13"	86	1	106-2-0710	13" HANGER BRG SUBWELD
40	1	100-2-3566	LOWER PIVOT W/A	87	1	900-11129	2-1/2 WIDE RIM MACH BUSHING
41	1	100-2-3568	INCLINE SPOUT W/A	88	1	901-01079	2" INSERT BEARING
42	1	100-2-3564	INSIDE PIVOT DOOR W/A	89	4	900-01055	5/16NC X 3/4 HEX BOLT G5
43	1	100-2-3585	OUTSIDE PIVOT DOOR W/A	90	4	900-01241	1/2-13 x 3-1/2 GR 5 HHCS
44	1	100-2-3586	OVERFLOW DOOR W/A	91	2	900-03439	3/8NC X 1-1/4 SERR FLANGE BOLT
45	2	100-2-3587	PIVOT DOOR PIN W/A	92	4	900-06137	5/16 NC SERR FLANGE NUT
46	1	100-2-3588	PIVOT DOOR HANDLE W/A	93	2	900-06139	3/8 NC SERR FLANGE NUT
47	1	100-3-4844	HINGE PIN	94	4	900-06504	1/2" NC TOPLOCK NUT

13 x 60, 70 & 80 Hopper and Inclined Tube

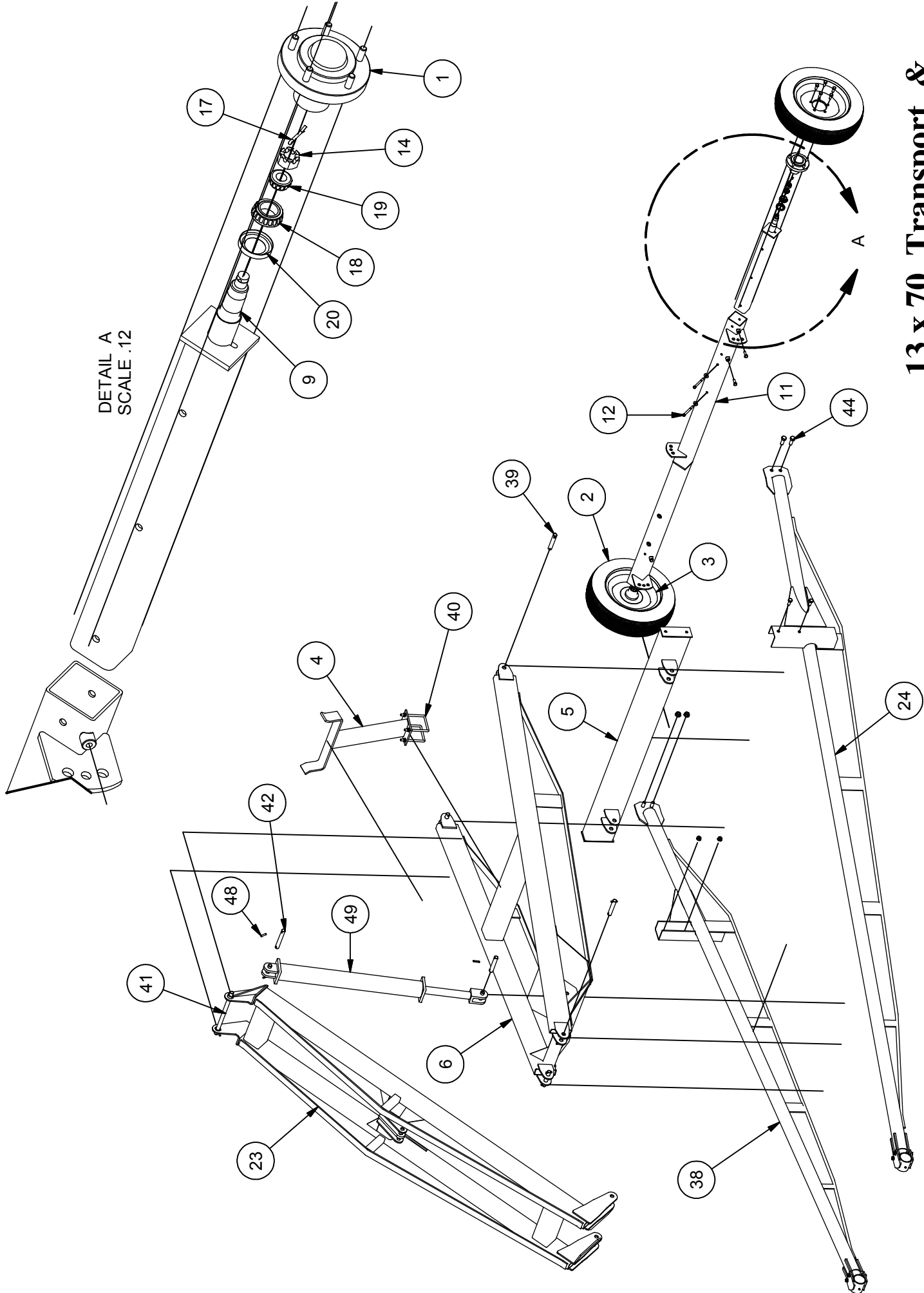

**13 x 70 Transport &
13 x 60 Transport ***

* The 13 x 60 Transport has (4) different parts then the 13 x 70

Parts List				Parts List			
ITEM	QTY	PART NUMBER	DESCRIPTION	ITEM	QTY	PART NUMBER	DESCRIPTION
1	2	100-2-1051	HUB, 5 HOLE	27	1	100-3-2357	TRUSS MOUNT
2	1	15" TIRE	15" TIRE	28	1	100-3-2506	TRUSS ROD
3	1	905-09078	RIM, 15" X 6" X 5 BOLT	29	1	100-3-4066	MOUNT, TRUSS
4	1	100-2-1295	TRANSPORT BRACE WELD	30	1	100-3-4067	MOUNT, TRUSS
5	1	100-2-1305	TUBE, REACH ARM	31	1	100-3-4076	TUBE CAP
6	1	100-2-1336 *	LOWER LIFT ARM W/A	32	1	100-3-4512	AXLE BRACKET, REACH ARM
7	1	100-2-2060	AXLE WELDMENT	33	2	100-3-4513	PIVOT BRACKET, REACH ARM
8	2	100-2-2058	AXLE EXTENSION	34	1	100-3-4514	REACH ARM TUBE
9	1	100-2-2057	SPINDLE WELD	35	1	100-3-4608	REACH ARM GUSSET
10	1	100-3-3733	TUBE	36	4	900-01750	1/2 X 1-1/4 GR 5 NC CRG BOLT
11	1	100-2-2059	AXLE WELD/ASSY	37	4	900-06143	1/2 NC SERR FLANGE NUT
12	4	900-01197	7/16NC X 4-1/2 GR5 HEX BOLT	38	1	100-2-2904 *	REACH ARM, 70ft, RH
13	10	900-01223	1/2-13 X 1-1/4 GR 5 HHCS	39	5	100-3-2400	PIN, HINGE
14	2	900-06060	7/8" -14NF SLOTTED HEX	40	2	100-3-2454	U-BOLT, 1/2" NC 5 X 6 LG
15	4	900-06141	7/16NC SERR FLANGE NUT	41	1	100-3-4031	TRANSPORT PIN
16	4	900-11034	7/16 USS FLAT WASHER	42	1	100-3-5198	CYLINDER PIN
17	2	900-23043	3/16 X 1-1/2 COTTER PIN	43	4	900-01341	5/8 NC X 1-1/2 HEX BOLT GR5
18	2	901-01015	BEARING CONE LM67048	44	4	900-01403	3/4NC X 2 HEX BOLT GR5
19	2	901-01023	BEARING CONE LM48548	45	4	900-06143	1/2 NC SERR FLANGE NUT
20	2	901-09002	SEAL - CR 17617	46	4	900-06145	5/8NC SERR FLANGE NUT
21	2	905-09003	HUB, 5 HOLE	47	4	900-06147	3/4 - 10 FLANGE NUT
22	2	905-09009	CAP, HUB	48	14	900-29220	3/8 X 1-3/4 ROLL PIN
23	1	100-2-2692 *	UPPER LIFT ARM W/A	49	1	905-21154	HYDRAULIC CYL.
24	1	100-2-2903 *	REACH ARM, 70ft, LH				
25	1	100-2-2905	MOUNT W/A, REACH ARM				
26	1	100-3-2356	TRUSS SUPPORT, LH				

* People who own 13 x 60 augers need to change the four highlighted part numbers per instructions on page 48.

13 x 70 Transport & 13 x 60 Transport *

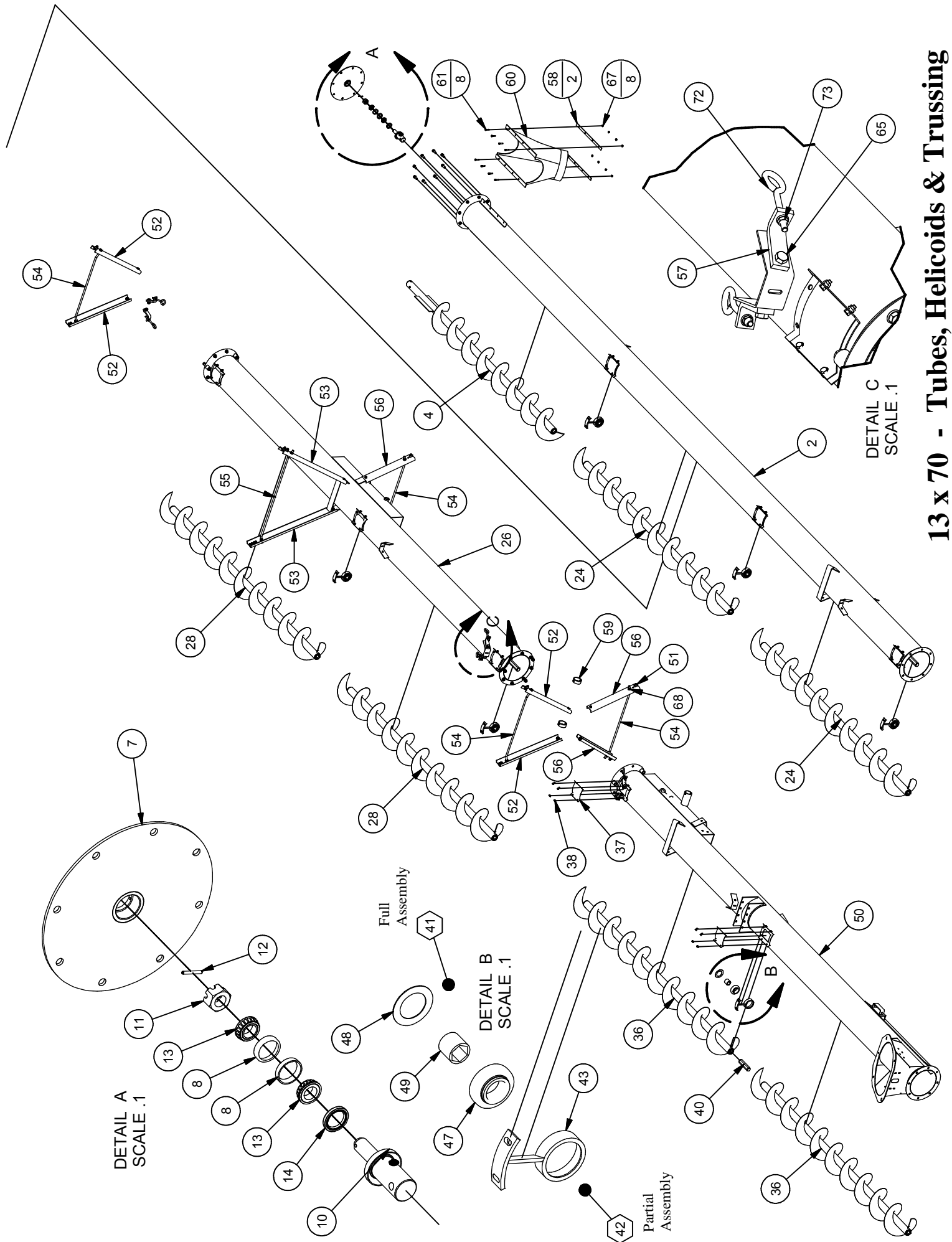

DETAIL A
SCALE .1

DETAIL B
SCALE .1

DETAIL C
SCALE .1

13 x 70 - Tubes, Helioids & Trussing

Parts List				Parts List			
ITEM	QTY	PART NUMBER	DESCRIPTION	ITEM	QTY	PART NUMBER	DESCRIPTION
1	1	100-2-2681	TOP TUBE ASSY., 13"	41	1	106-2-0712	HANGER BRG ASSY, HEX 13"
2	1	100-2-2669	TOP TUBE WELD, 13"	42	1	106-2-0711	13" HANGER BEARING ASSY
3	3	100-3-1113	COVER, ACCESS 13"	43	1	106-2-0710	13" HANGER BRG SUBWELD
4	1	100-2-2819	TOP HELICOID WELD, 13"	44	1	106-3-1137	COLLAR FOR 2" BRG, 13"
5	1	100-2-2680	TOP PLATE ASSEMBLY	45	1	106-3-0507	HANGER BRG SUPPORT, 13"
6	1	100-2-2679	TOP PLATE SUB ASSEMBLY	46	1	100-3-4383	ROD, 13" HANGER
7	1	100-2-2660	TOP PLATE WELDMENT	47	1	901-01079	2" INSERT BEARING
8	2	901-01016	LM67010 CUP	48	1	900-11129	2-1/2 WIDE RIM MACH BUSHING
9	1	100-3-3487	SHAFT, BEARING	49	1	100-3-4208	13" AUGER HEX BUSHING
10	1	100-3-3492	CAP, BEARING	50	1	100-2-3346	BTTM TUBE WELD, 13 X 70 1410 MECH. DR.
11	1	900-06066	NUT, CASTLE - 1"	51	12	100-2-3958	CLAMP, TRUSS CABLE
12	1	900-29182	1/4 X 2 ROLL PIN	52	4	100-3-2404	TRUSS STANDOFF ARM 30"
13	2	901-01015	BEARING CONE LM67048	53	2	100-3-2405	TRUSS STANDOFF ARM, 42"
14	1	901-09203	SEAL	54	4	100-3-2413	BAR, TRUSS SUPPORT
15	1	905-09009	CAP, HUB	55	1	100-3-2414	TRUSS SUPPORT BOLT, 46"
16	8	900-01341	5/8 NC X 1-1/2 HEX BOLT GR5	56	4	100-3-2560	TRUSS STANDOFF ARM 24"
17	8	900-06508	5/8 - 11 TOP LOCK HEX NUT	57	8	100-3-3613	TRUSS ANCHOR STRAP
18	3	100-3-4209	1-1/2 HEX CONNECTING SHAFT	58	2	100-3-3864	BAR, SPOUT
19	3	106-2-0712	HANGER BRG ASSY, HEX 13"	59	2	100-3-4050	COLLAR, TRANSPORT
20	6	900-03439	3/8NC X 1-1/4 SERR FLANGE BOLT	60	1	100-3-5377	13" DISCHARGE SPOUT, DRILLED
21	6	900-06139	3/8 NC SERR FLANGE NUT	61	8	900-01113	3/8NC X 1-1/2 HEX BOLT G5
22	12	900-01055	5/16NC X 3/4 HEX BOLT G5	62	10	900-01221	1/2NC X 1 HEX BOLT GR5
23	12	900-06137	5/16 NC SERR FLANGE NUT	63	2	900-01337	5/8NC X 1 HHCS
24	2	100-2-2818	CENTER HELICOID WELD 13"	64	10	900-01339	5/8-11 X 1-1/4 GR 5 HHCS
25	1	100-2-2682	13 X 70 MIDDLE TUBE ASSY.	65	8	900-01341	5/8 NC X 1-1/2 HEX BOLT GR5
26	1	100-2-2668 *	INT. TUBE W/A 13X70	66	6	900-01363	5/8-11 X 4-1/2 GR 5 HHCS ZP
27	3	100-3-1113	COVER, ACCESS 13"	67	8	900-06139	3/8 NC SERR FLANGE NUT
28	2	100-2-2818	CENTER HELICOID WELD 13"	68	56	900-06145	5/8NC SERR FLANGE NUT
29	2	100-3-4209	1-1/2 HEX CONNECTING SHAFT	69	1	100-3-2457	1/4" CABLE, HOPPER LIFT
30	2	106-2-0712	HANGER BRG ASSY, HEX 13"	70	2	100-3-2502	3/8" X 50' CABLE
31	4	900-03439	3/8NC X 1-1/4 SERR FLANGE BOLT	71	1	100-3-3674	3/8" X 104' CABLE
32	4	900-06139	3/8 NC SERR FLANGE NUT	72	8	100-3-0148	EYEBOLT, 1/2" NC
33	12	900-01055	5/16NC X 3/4 HEX BOLT G5	73	16	900-06143	1/2 NC SERR FLANGE NUT
34	12	900-06137	5/16 NC SERR FLANGE NUT				
35	1	100-2-3345	13 X 70 BOTTOM TUBE ASSY				
36	2	100-2-2818	CENTER HELICOID WELD 13"				
37	2	100-3-1113	COVER, ACCESS 13"				
38	8	900-01055	5/16NC X 3/4 HEX BOLT G5				
39	8	900-06137	5/16 NC SERR FLANGE NUT				
40	1	100-3-4209	1-1/2 HEX CONNECTING SHAFT				

13 x 70 - Tubes, Helicoids & Trussing

* People who own 13 x 60 mechanical drive augers need to change the numbers highlighted in pale blue per the instructions on page 48.

13 x 80 - Model 1410 - Mechanical Drive

For purposes of this owners manual and the lengthy process of exploding views of individual augers we are showing the 13 x 70 and identifying the differences of the 13 x 80 were applicable. These augers are large and contain many parts. To get reasonable size and clarity we have divided the auger into four sections, eight pages. See pages 49 through 56.

To be specific about the 13 x 80, it obviously is 10 feet longer. It's tube sections are comprised of (1) thirty foot bottom tube, (1) twenty foot center tube and (1) thirty foot top tube v. (2) twenties and a thirty to total 70 for the one shown on page 55. The top or upper tubes are common. Helicoids are 10 foot in length; therefore the 80 foot auger will have one more helicoid section in it.

Pages 49 through 52 of the manual are common for both the 13 x 70 and the 13 x 80.

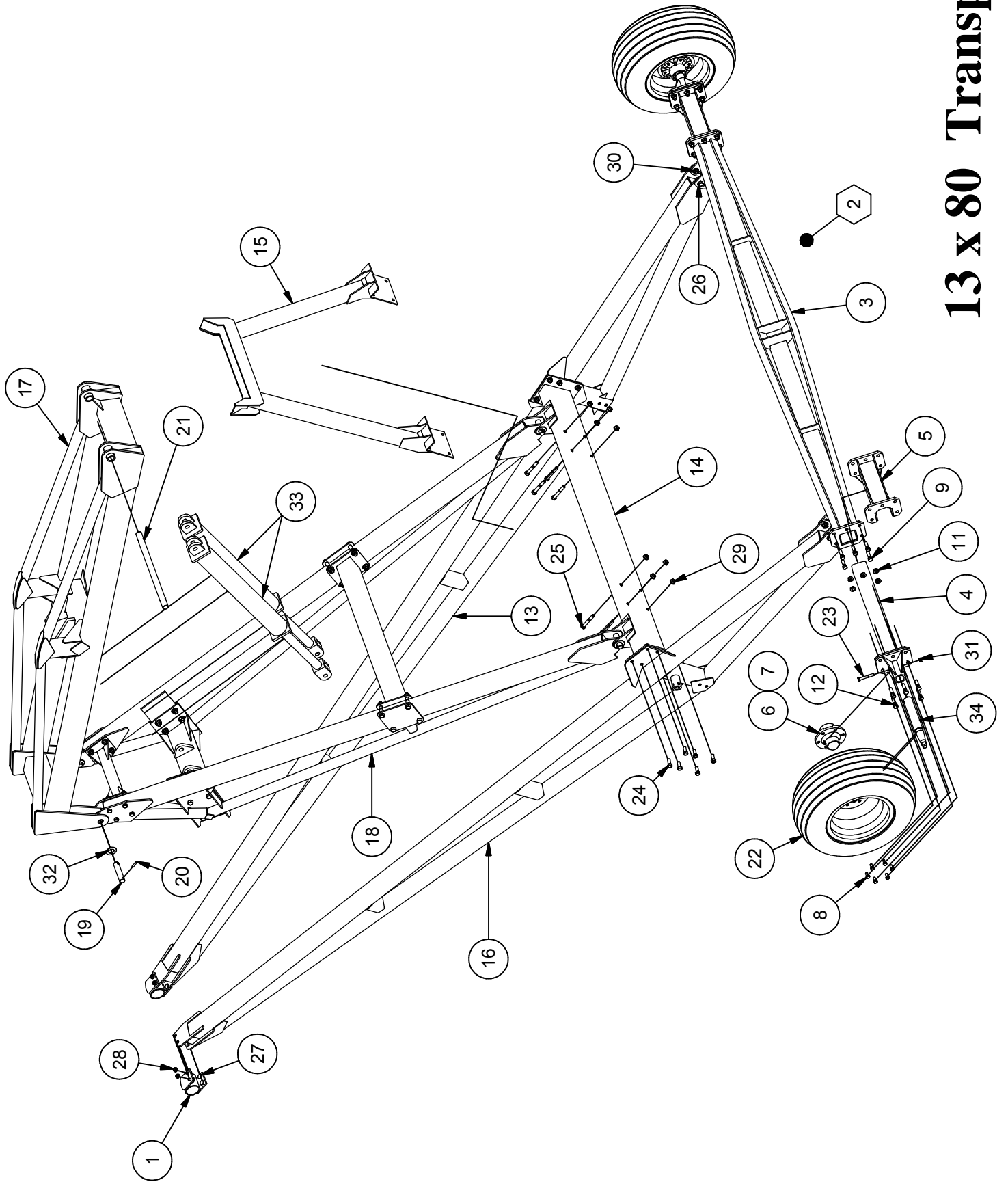

13 x 80 Transport

Parts List			
ITEM	QTY	PART NUMBER	DESCRIPTION
1	2	100-2-2905	MOUNT W/A, REACH ARM
2	1	100-2-3195	AXLE ASSEMBLY
3	1	100-2-3197	AXLE WELDMENT
4	2	100-2-3212	AXLE EXTENSION WELD
5	2	100-2-3214	AXLE EXTENSION WELD
6	2	603-2-0096	HUB ASSEMBLY
7	1	905-15001	1/8 NPT ST Zerkl
8	6	900-01221	1/2NC X 1 HEX BOLT GR5
9	10	900-01345	5/8 x 2 HEX BOLT GR5
10	5	900-01349	5/8-11 X 2-1/2 GR 5 HHCS
11	20	900-06145	5/8NC SERR FLANGE NUT
12	5	900-01347	5/8-11 x 2-1/4 GR 5 HHCS
13	1	100-2-3196	REACH ARM WELDMENT, RH
14	1	100-2-3198	LIFT ARM MOUNT WELDMENT
15	1	100-2-3208	TRANSPORT REST WELDMENT
16	1	100-2-3210	REACH ARM WELDMENT, LH
17	1	100-2-3337	UPPER LIFT ARM W/A
18	1	100-2-3338	LOWER LIFT ARM ASSEMBLY
19	4	100-3-5191	LIFT ARM PIN, 5-1/2"
20	2	900-29220	3/8 X 1-3/4 ROLL PIN
21	1	100-3-5195	LIFT ARM PIN
22	2	603-2-0097	WHEEL & TIRE ASSEMBLY
23	2	900-01241	1/2-13 x 3-1/2 GR 5 HHCS
24	12	900-01341	5/8 NC X 1-1/2 HEX BOLT GR5
25	8	900-01361	5/8-11 X 4 GR 5 HHCS
26	8	900-01399	3/4 X 1-1/2 GR 5 HHCS
27	8	900-01750	1/2 X 1-1/4 GR 5 NC CRG BOLT
28	8	900-06143	1/2 NC SERR FLANGE NUT
29	20	900-06145	5/8NC SERR FLANGE NUT
30	8	900-06147	3/4 - 10 FLANGE NUT
31	2	900-06504	1/2" NC TOPLOCK NUT
32	8	900-11042	1-1/4 USS FLAT WASHER
33	2	905-21154	HYD. CYL.
34	1	603-2-0099	SPINDLE PKG.

13 x 80 Transport

13 x 80 Tubes, Helicoids and Trussing

DETAIL B
SCALE .04

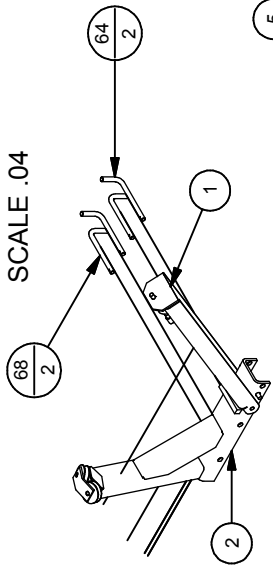

DETAIL C
SCALE .055

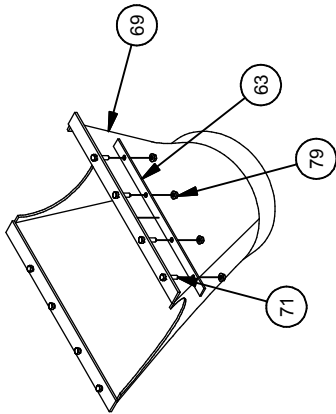

DETAIL A
SCALE .06

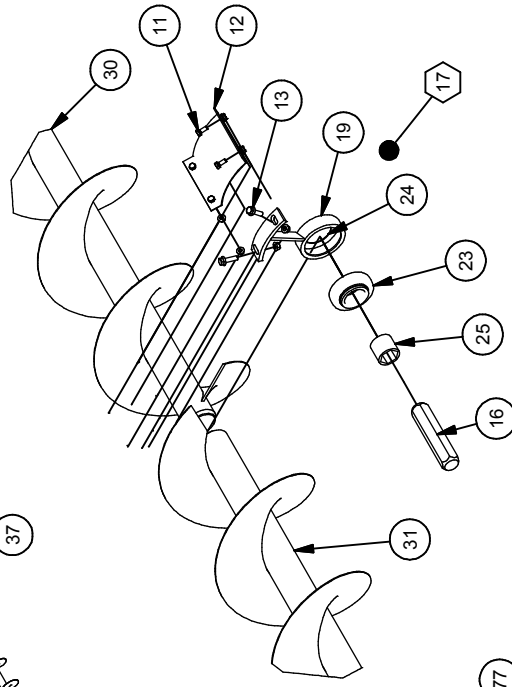

DETAIL D
SCALE .06

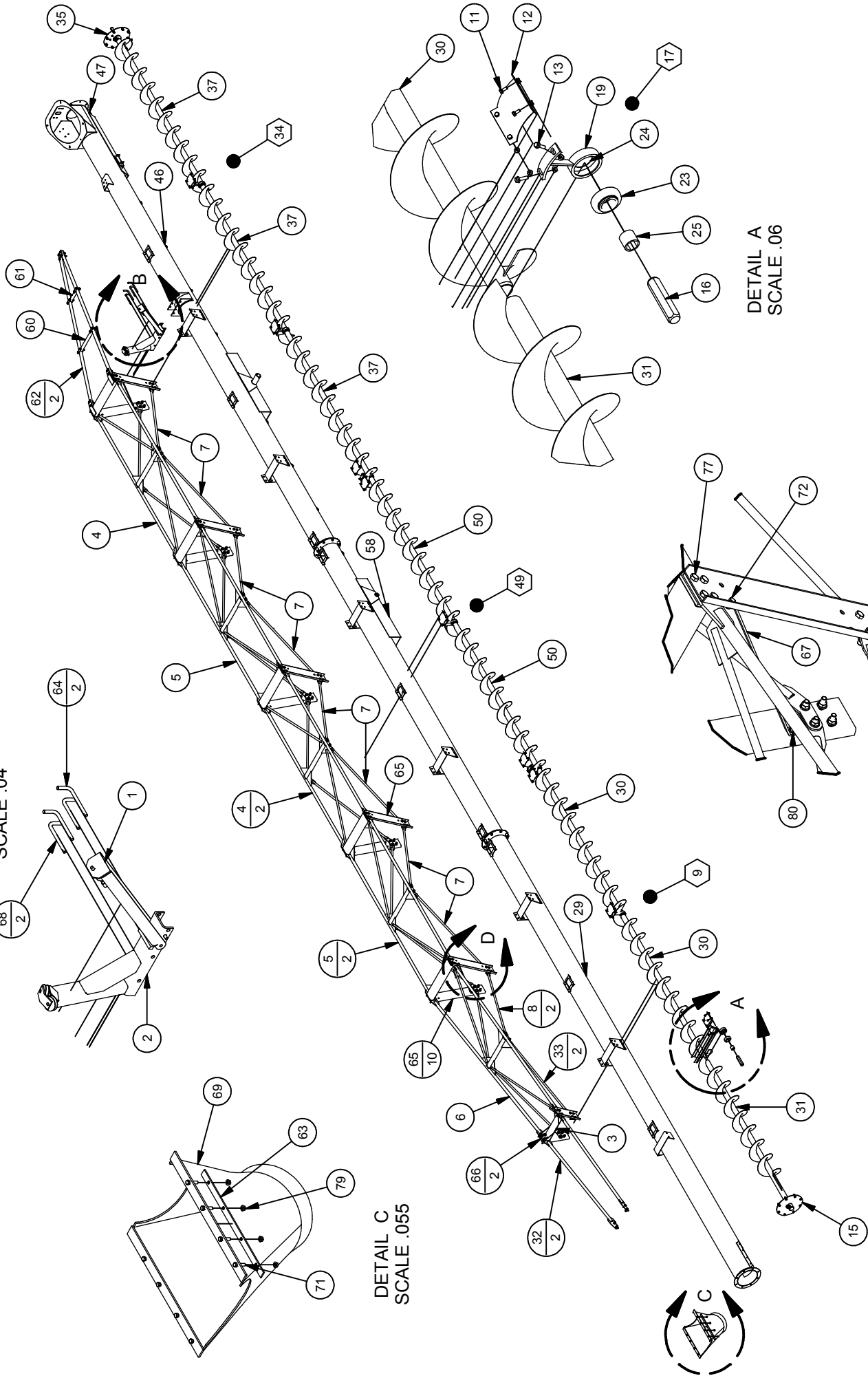
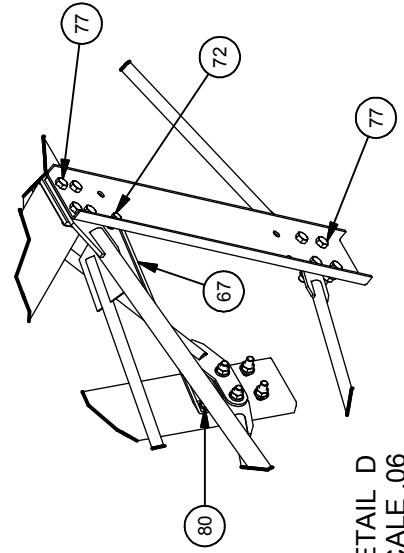

Parts List				Parts List			
ITEM	QTY	PART NUMBER	DESCRIPTION	ITEM	QTY	PART NUMBER	DESCRIPTION
1	1	100-2-2843	HOPPER LIFT ARM WELD, 13"	45	4	900-06139	3/8 NC SERR FLANGE NUT
2	1	100-2-2874	LIFT ARM MOUNT W/A, 13"	46	1	100-2-3571	BTM TUBE W/A 13X80 1410
3	1	100-2-3089	END TRUSS CROSS BRACE W/A 13"	47	1	100-2-3574	CLEAN-OUT DOOR W/A 13" AUGER
4	2	100-2-3316	TRUSS WELD, OUTSIDE 13"	48	2	900-01063	5/16-18 X 1-1/2 GR 5 HHCS
5	2	100-2-3320	TRUSS WELD, 13" INSIDE	49	1	100-2-3572	CENTER TUBE ASSY 13X80 1410
6	1	100-2-3321	END TRUSS WELDMENT, 13"	50	2	100-2-2818	CENTER HELICOID WELD 13"
7	16	100-2-3534	TRUSS WELD, 68.50 PIPE LENGTH	51	1	100-3-4209	1-1/2 HEX CONNECTING SHAFT
8	2	100-2-3535	TRUSS WELD, 64.85" PIPE LENGTH	52	2	106-2-0712	HANGER BRG ASSY, HEX 13"
9	1	100-2-3538	30' TOP TUBE ASSY 13" RIGID TRUSS	53	3	100-3-1113	COVER, ACCESS 13"
10	12	900-06137	5/16 NC SERR FLANGE NUT	54	12	900-01055	5/16NC X 3/4 HEX BOLT G5
11	12	900-01055	5/16NC X 3/4 HEX BOLT G5	55	12	900-06137	5/16 NC SERR FLANGE NUT
12	3	100-3-1113	COVER, ACCESS 13"	56	4	900-03439	3/8NC X 1-1/4 SERR FLANGE BOLT
13	6	900-03439	3/8NC X 1-1/4 SERR FLANGE BOLT	57	4	900-06139	3/8 NC SERR FLANGE NUT
14	6	900-06139	3/8 NC SERR FLANGE NUT	58	1	100-2-3573	CENTER TUBE W/A 13X80 1410
15	1	100-2-2680	TOP PLATE ASSEMBLY	59	1	100-2-3578	END CROSS CHANNEL W/A, 13"
16	3	100-3-4209	1-1/2 HEX CONNECTING SHAFT	60	1	100-2-3579	CROSS BRACE W/A LONG
17	3	106-2-0712	HANGER BRG ASSY, HEX 13"	61	1	100-2-3580	CROSS BRACE W/A, SHORT
18	1	106-2-0711	13" HANGER BEARING ASSY	62	2	100-2-3583	LOWER END TRUSS W/A
19	1	106-2-0710	13" HANGER BRG SUBWELD	63	2	100-3-3864	BAR, SPOUT
20	1	106-3-1137	COLLAR FOR 2" BRG, 13"	64	2	100-3-4747	PIN, HOPPER ARM M/TG, 13"
21	1	106-3-0507	HANGER BRG SUPPORT, 13"	65	10	100-3-4846	TRUSS STANDOFF CHANNEL
22	1	100-3-4383	ROD, 13" HANGER	66	2	100-3-4862	TRUSS STANDOFF, SHORT
23	1	901-01079	2" INSERT BEARING	67	2	100-3-4938	TRUSS BRACE BAR
24	1	900-11129	2-1/2 WIDE RIM MACH BUSHING	68	2	100-3-5258	HOPPER ARM MOUNTING PIN
25	1	100-3-4208	13" AUGER HEX BUSHING	69	1	100-3-5377	13" DISCHARGE SPOUT, DRILLED
26	8	900-01341	5/8 NC X 1-1/2 HEX BOLT GR5	70	4	100-3-5856	CROSS TUBE MOUNT TAB
27	10	900-06508	5/8 - 11 TOP LOCK HEX NUT	71	8	900-01113	3/8NC X 1-1/2 HEX BOLT G5
28	2	900-01361	5/8-11 X 4 GR 5 HHCS	72	4	900-01221	1/2NC X 1 HEX BOLT GR5
29	1	100-2-3539	30' TOP TUBE W/A 13" RIGID TRUSS	73	8	900-01233	1/2-13 X 2-1/2 GR 5 HHCS ZP
30	2	100-2-2818	CENTER HELICOID WELD, 13"	74	8	900-01237	1/2-13 X 3 GR 5 HHCS
31	1	100-2-2819	TOP HELICOID WELD, 13"	75	12	900-01337	5/8NC X 1 HHCS
32	2	100-2-3555	END TRUSS WELD, 68.52 PIPE L	76	30	900-01341	5/8 NC X 1-1/2 HEX BOLT GR5
33	2	100-2-3564	TRUSS WELD, 55.27" PIPE LENGTH	77	92	900-01345	5/8 x 2 HEX BOLT GR5
34	1	100-2-3570	BOTTOM TUBE ASSY 13X80 1410	78	6	900-01363	5/8-11 X 4-1/2 GR 5 HHCS ZP
35	1	100-2-2824	BEARING PLATE ASSY, 13"	79	8	900-06139	3/8 NC SERR FLANGE NUT
36	2	106-2-0712	HANGER BRG ASSY, HEX 13"	80	20	900-06143	1/2 NC SERR FLANGE NUT
37	3	100-2-2818	CENTER HELICOID WELD 13"	81	143	900-06145	5/8NC SERR FLANGE NUT
38	2	100-3-4209	1-1/2 HEX CONNECTING SHAFT				
39	3	100-3-1113	COVER, ACCESS 13"				
40	12	900-01055	5/16NC X 3/4 HEX BOLT G5				
41	14	900-06137	5/16 NC SERR FLANGE NUT				
42	8	900-01341	5/8 NC X 1-1/2 HEX BOLT GR5				
43	8	900-06508	5/8 - 11 TOP LOCK HEX NUT				
44	4	900-03439	3/8NC X 1-1/4 SERR FLANGE BOLT				

13 x 80 Tubes, Helicoids and Trussing

PARTS LIST			
ITEM	QTY	PART NUMBER	DESCRIPTION
1	1	100-2-2843	HOPPER LIFT ARM WELD, 13"
2	1	100-2-3604	LIFT ARM MOUNT W/A, 13"
3	1	100-2-3605	PULLEY SUBWELD
4	1	100-3-4747	PIN, HOPPER ARM MTG, 13"
5	2	100-3-5258	HOPPER ARM MOUNTING PIN
6	2	100-3-5945	LATCH BAR
7	1	100-3-5946	HANDLE TUBE
8	1	100-3-5949	HOPPER LIFT ARM LOCK TUBE
9	1	900-01241	1/2-13 x 3-1/2 GR 5 HHCS
10	2	900-01353	5/8-11 X 3 HHCS
11	1	900-01357	5/8-11 X 3-1/2 GR 5 HHCS
12	1	900-06143	1/2 NC SERR FLANGE NUT
13	3	900-06145	5/8NC SERR FLANGE NUT
14	3	900-25005	R HITCH PIN #9

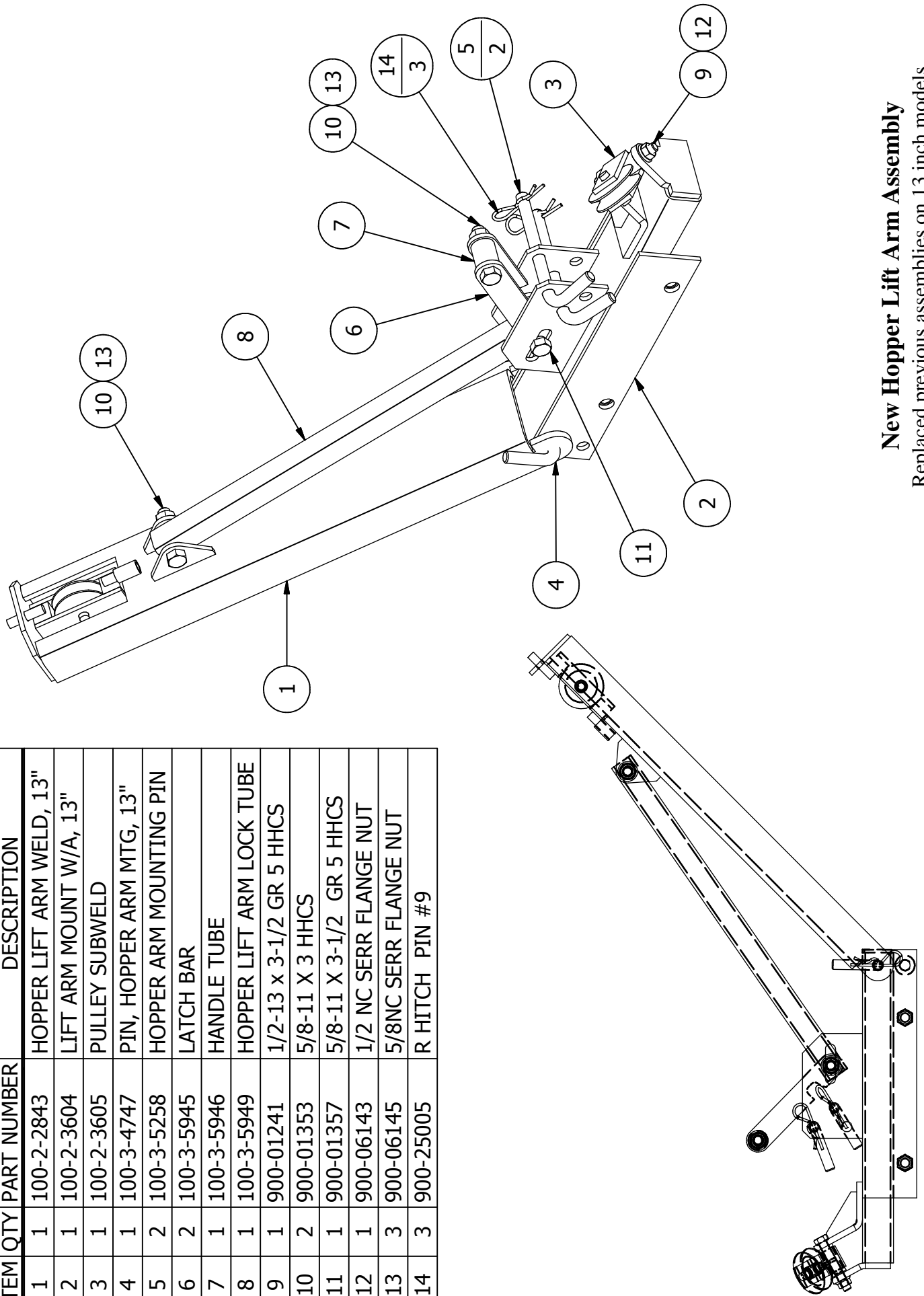

61a

New Hopper Lift Arm Assembly
 Replaced previous assemblies on 13 inch models
 Effectivity date - May 2011

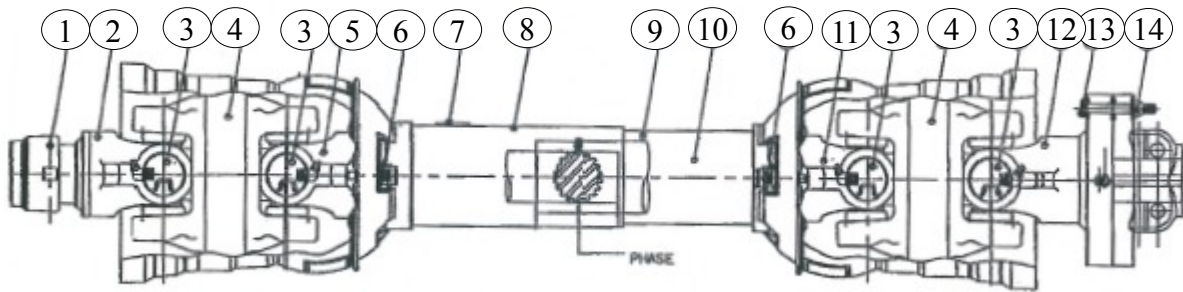

TRACTOR PTO SHAFT COMPONENTS

(Weasler 55R – Double, Cat. 6, 50 Degree
Constant Velocity Universal Joint)

Parts List			
Item	Part Number	Description	Qty
1	903-18007	Safety Slide Lock Repair Kit # 26-1520	1
2	903-18008	Safety Slide Lock Yoke Assembly # 55241-1612	1
3	903-18064	Cross and Bearing Kit # 03-10050	4
4	903-18065	Center Housing # 55251-1599	2
5	903-18012	Yoke and Shaft # 99-19545	1
6	903-18066	Nylon Repair Kit # 19-5121	2
7	903-18016	Safety Sing # 13-10021	1
8	903-18067	Outer Guard # 97-22164	1
9	903-18068	Inner Guard # 96-22164	1
10	903-18018	Safety Sign # 13-10022	1
11	903-18019	Yoke, Tube & Slip Sleeve # 98-19545	1
12	903-18023	Ball Shear Assembly # 40-10027	1
13	900-01071	5/16 UNC x 2-1/2 Hex Bolt Grade 5 # 11-10471	1
14	900-06498	5/16 UNC Lock Nut # 11-10044	1

903-18069	PTO Half, Tractor End # 93-22164	1
903-18070	PTO Half, Implement End # 92-22164	1
903-18048	PTO Shaft, Complete # 260-22164	1

HARDWARE

NUTS		WASHERS	
PART NO.	DESCRIPTION	PART NO.	DESCRIPTION
900-06194	3/16 NC Hex Nut	900-11007	3/16 Lock Washer
900-06001	1/4 NC Hex Nut	900-11009	1/4 Lock Washer
900-06003	5/16 NC Hex Nut	900-11010	5/16 Lock Washer
900-06005	3/8 NC Hex Nut	900-11011	3/8 Lock Washer
900-06007	7/16 NC Hex Nut	900-11012	7/16 Lock Washer
900-06009	1/2 NC Hex Nut	900-11013	1/2 Lock Washer
900-06010	1/2 NF Hex Nut	900-11014	9/16 Lock Washer
900-06011	9/16 NC Hex Nut	900-11015	5/8 Lock Washer
900-06013	5/8 NC Hex Nut	900-11017	3/4 Lock Washer
900-06015	3/4 NC Hex Nut	900-11019	7/8 Lock Washer
900-06017	7/8 NC Hex Nut	900-11021	1" Lock Washer
900-06019	1" NC Hex Nut	900-11023	1-1/8 Lock Washer
900-06023	1-1/4 NC Hex Nut	900-11025	1-1/4 Lock Washer
900-06025	1-3/8 NC Hex Nut	900-11029	1-1/2 Lock Washer
900-06027	1-1/2 NC Hex Nut		
900-06056	5/8 NF Slotted Hex Nut	900-11030	3/16 Flat Washer
900-06058	3/4 NF Slotted Hex Nut	900-11031	1/4 Flat Washer
900-06060	7/8 NF Slotted Hex Nut	900-11032	5/16 Flat Washer
900-06062	1" NF Slotted Hex Nut	900-11033	3/8 Flat Washer
900-06065	1-1/4 NC Slotted Hex Nut	900-11034	7/16 Flat Washer
900-06066	1-1/4 NF Slotted Hex Nut	900-11035	1/2 Flat Washer
900-06070	1-1/2 NF Slotted Hex Nut	900-11036	9/16 Flat Washer
		900-11037	5/8 Flat Washer
900-06135	1/4 NC Flanged Whiz Lock Nut	900-11038	3/4 Flat Washer
900-06137	5/16 NC Flanged Whiz Lock Nut	900-11039	7/8 Flat Washer
900-06139	3/8 NC Flanged Whiz Lock Nut	900-11040	1" Flat Washer
900-06141	7/16 NC Flanged Whiz Lock Nut	900-11041	1-1/8 Flat Washer
900-06143	1/2 NC Flanged Whiz Lock Nut	900-11042	1-1/4 Flat Washer
900-06145	5/8 NC Flanged Whiz Lock Nut	900-11044	1-1/2 Flat Washer
900-06270	3/8 NC Jam Nut		
900-06276	1/2 NC Jam Nut		
900-06280	5/8 NC Jam Nut		
900-06282	3/4 NC Jam Nut		
900-06284	7/8 NC Jam Nut		
900-06286	1" NC Jam Nut		
900-06288	1-1/8 NC Jam Nut		
900-06292	1-3/8 NC Jam Nut		
900-06496	1/4 NC Top Lock Nut		
900-06498	5/16 NC Top Lock Nut		
900-06500	3/8 NC Top Lock Nut		
900-06502	7/16 NC Top Lock Nut		
900-06504	1/2 NC Top Lock Nut		
900-06508	5/8 NC Top Lock Nut		
900-06510	3/4 NC Top Lock Nut		
900-06512	7/8 NC Top Lock Nut		
900-06514	1" NC Top Lock Nut		
900-06518	1-1/4 NC Top Lock Nut		

INDEX

Part Number	Page
100-2-1051	50
100-2-1051	54
100-2-1295	50
100-2-1295	54
100-2-1305	50
100-2-1305	54
100-2-1336	48
100-2-1336	50
100-2-1336	54
100-2-2057	54
100-2-2058	54
100-2-2059	54
100-2-2060	50
100-2-2060	54
100-2-2657	50
100-2-2660	56
100-2-2668	48
100-2-2668	56
100-2-2669	56
100-2-2679	56
100-2-2680	56
100-2-2680	61
100-2-2681	56
100-2-2682	56
100-2-2692	48
100-2-2692	50
100-2-2692	54
100-2-2709	52
100-2-2747	52
100-2-2760	50
100-2-2798	52
100-2-2800	52
100-2-2801	50
100-2-2801	52
100-2-2804	52

Part Number	Page
100-2-2806	52
100-2-2807	52
100-2-2818	56
100-2-2818	56
100-2-2818	56
100-2-2818	61
100-2-2818	61
100-2-2818	61
100-2-2819	56
100-2-2819	61
100-2-2822	50
100-2-2824	50
100-2-2824	61
100-2-2843	61
100-2-2843	61a
100-2-2874	61
100-2-2903	48
100-2-2903	50
100-2-2903	54
100-2-2904	48
100-2-2904	50
100-2-2904	54
100-2-2905	54
100-2-2905	59
100-2-2925	50
100-2-3064	50
100-2-3067	50
100-2-3069	50
100-2-3077	50
100-2-3078	50
100-2-3079	50
100-2-3089	61
100-2-3126	50
100-2-3128	50
100-2-3131	50

Part Number	Page
100-2-3195	59
100-2-3196	59
100-2-3197	59
100-2-3198	59
100-2-3208	59
100-2-3210	59
100-2-3212	59
100-2-3214	59
100-2-3247	52
100-2-3248	52
100-2-3290	50
100-2-3316	61
100-2-3320	61
100-2-3321	61
100-2-3336	52
100-2-3337	59
100-2-3338	59
100-2-3345	56
100-2-3346	48
100-2-3346	56
100-2-3364	52
100-2-3511	50
100-2-3534	61
100-2-3535	61
100-2-3538	61
100-2-3539	61
100-2-3555	61
100-2-3564	61
100-2-3566	52
100-2-3568	52
100-2-3570	61
100-2-3571	61
100-2-3572	61
100-2-3573	61
100-2-3574	61

INDEX

Part Number	Page
100-2-3575	50
100-2-3575	52
100-2-3576	50
100-2-3576	52
100-2-3577	52
100-2-3578	61
100-2-3579	61
100-2-3580	61
100-2-3583	61
100-2-3584	52
100-2-3585	52
100-2-3586	52
100-2-3587	52
100-2-3588	52
100-2-3597	52
100-2-3604	61a
100-2-3605	61a
100-2-3958	56
100-3-0148	50
100-3-0148	56
100-3-1113	52
100-3-1113	56
100-3-1113	56
100-3-1113	56
100-3-1113	61
100-3-1113	61
100-3-1113	61
100-3-1367	15
100-3-2356	54
100-3-2357	54
100-3-2400	50
100-3-2400	54
100-3-2404	56
100-3-2405	56
100-3-2413	56

Part Number	Page
100-3-2414	56
100-3-2454	50
100-3-2454	54
100-3-2457	56
100-3-2502	48
100-3-2502	56
100-3-2506	54
100-3-2560	56
100-3-3292	52
100-3-3487	56
100-3-3492	56
100-3-3510	52
100-3-3593	15
100-3-3613	56
100-3-3623	15
100-3-3674	48
100-3-3674	56
100-3-3675	52
100-3-3692	17
100-3-3696	15
100-3-3733	54
100-3-3864	56
100-3-3864	61
100-3-4000	52
100-3-4031	54
100-3-4050	56
100-3-4066	54
100-3-4067	54
100-3-4076	54
100-3-4109	52
100-3-4208	56
100-3-4208	61
100-3-4209	56
100-3-4209	56
100-3-4209	56
100-3-4209	56
100-3-4209	61

Part Number	Page
100-3-4209	61
100-3-4209	61
100-3-4278	50
100-3-4282	50
100-3-4283	50
100-3-4287	50
100-3-4291	50
100-3-4334	52
100-3-4371	52
100-3-4383	56
100-3-4383	61
100-3-4460	17
100-3-4462	17
100-3-4465	52
100-3-4466	17
100-3-4467	52
100-3-4468	52
100-3-4512	54
100-3-4513	54
100-3-4514	54
100-3-4608	54
100-3-4747	61
100-3-4747	61a
100-3-4820	50
100-3-4821	50
100-3-4822	50
100-3-4826	50
100-3-4831	50
100-3-4838	50
100-3-4841	50
100-3-4844	50
100-3-4844	52
100-3-4846	61
100-3-4862	61
100-3-4937	16

INDEX

Part Number	Page
100-3-4938	61
100-3-4939	17
100-3-4942	52
100-3-5191	59
100-3-5195	59
100-3-5255	50
100-3-5258	50
100-3-5258	61
100-3-5258	61a
100-3-5340	52
100-3-5341	52
100-3-5377	56
100-3-5377	61
100-3-5512	52
100-3-5514	52
100-3-5831	50
100-3-5839	52
100-3-5856	61
100-3-5865	52
100-3-5873	52
100-3-5874	52
100-3-5882	52
100-3-5886	52
100-3-5887	52
100-3-5889	50
100-3-5890	50
100-3-5891	52
100-3-5896	50
100-3-5897	50
100-3-5899	52
100-3-5945	61a
100-3-5946	61a
100-3-5949	61a

Part Number	Page
106-2-0710	52
106-2-0710	56
106-2-0710	61
106-2-0711	52
106-2-0711	56
106-2-0711	61
106-2-0712	56
106-2-0712	56
106-2-0712	56
106-2-0712	61
106-2-0712	61
106-2-0712	61
106-3-0507	56
106-3-0507	61
106-3-1137	56
106-3-1137	61
15" TIRE	54
200-2-0705	50
505-3-0315	16
603-2-0096	59
603-2-0097	59
603-2-0099	59
900-01055	50
900-01055	52
900-01055	52
900-01055	56
900-01055	56
900-01055	56
900-01055	61
900-01055	61
900-01055	61
900-01059	52
900-01063	61
900-01071	62
900-01105	50

Part Number	Page
900-01113	50
900-01113	56
900-01113	61
900-01121	52
900-01129	52
900-01141	52
900-01197	54
900-01221	52
900-01221	56
900-01221	59
900-01221	61
900-01223	54
900-01225	50
900-01233	52
900-01233	61
900-01237	61
900-01241	52
900-01241	59
900-01241	61a
900-01247	50
900-01249	50
900-01337	56
900-01337	61
900-01339	50
900-01339	56
900-01341	50
900-01341	54
900-01341	56
900-01341	56
900-01341	59
900-01341	61
900-01341	61
900-01341	61
900-01343	50
900-01345	59

INDEX

Part Number	Page
900-01345	61
900-01347	59
900-01349	50
900-01349	59
900-01353	61a
900-01357	61a
900-01361	59
900-01361	61
900-01363	56
900-01363	61
900-01399	59
900-01403	50
900-01403	54
900-01407	52
900-01411	50
900-01423	52
900-01694	52
900-01750	54
900-01750	59
900-03419	52
900-03436	50
900-03436	52
900-03438	50
900-03438	52
900-03438	52
900-03439	52
900-03439	52
900-03439	56
900-03439	56
900-03439	61
900-03439	61
900-03439	61
900-06060	54
900-06066	56
900-06137	52

Part Number	Page
900-06137	52
900-06137	52
900-06137	56
900-06137	56
900-06137	56
900-06137	61
900-06137	61
900-06137	61
900-06139	50
900-06139	52
900-06139	52
900-06139	52
900-06139	52
900-06139	56
900-06139	56
900-06139	56
900-06139	61
900-06139	61
900-06139	61
900-06139	61
900-06141	54
900-06143	50
900-06143	52
900-06143	54
900-06143	54
900-06143	56
900-06143	59
900-06143	61
900-06143	61a
900-06145	50
900-06145	54
900-06145	56
900-06145	59
900-06145	59
900-06145	61

Part Number	Page
900-06145	61a
900-06147	50
900-06147	54
900-06147	59
900-06498	62
900-06500	52
900-06504	52
900-06504	52
900-06504	59
900-06508	56
900-06508	61
900-06508	61
900-06510	50
900-06510	52
900-06510	52
900-11013	52
900-11033	52
900-11034	54
900-11042	59
900-11129	52
900-11129	56
900-11129	61
900-16361	52
900-23023	50
900-23043	54
900-25005	61a
900-27024	52
900-29082	52
900-29182	56
900-29220	50
900-29220	54
900-29220	59
901-01015	54
901-01015	56
901-01016	56

INDEX

Part Number	Page
901-01023	54
901-01079	52
901-01079	56
901-01079	61
901-01101	52
901-01301	50
901-01311	50
901-01313	50
901-09002	54
901-09203	56
901-09220	50
903-15633	52
903-15634	50
903-18007	62
903-18008	62
903-18012	62
903-18016	62
903-18018	62
903-18019	62
903-18023	62
903-18048	50
903-18048	62
903-18064	62
903-18065	62
903-18066	62
903-18067	62
903-18068	62
903-18069	62
903-18070	62
905-01159	52
905-03080	52
905-09003	54
905-09009	54
905-09009	56
905-09078	54

Part Number	Page
905-09134	52
905-15001	59
905-21154	50
905-21154	54
905-21154	59
905-23024	50



701 Lenham Ave. - P.O. Box 647

Cooperstown, ND 58425

Office (701) 797-2700

Fax (701) 797-2584

Toll Free (800) 797-1883

www.sheyennemfg.com